

Infantry

September-December 1999



The Case for Squad Sharpshooters (Page 23)
Task Force Faith at the Chosin Reservoir (Page 29)

Infantry

PB 7-99-3

September-December 1999

Volume 89, Number 3

MG JOHN M. Le MOYNE
Commandant, The Infantry School

RUSSELL A. ENO
Editor, INFANTRY

MARIE B. EDGERTON
Deputy Editor

BETTY J. BYRD
Editorial Assistant

JULIO RIVERA
Graphic Artist

This medium is approved for official dissemination of material designed to keep individuals within the Army knowledgeable of current and emerging developments within their areas of expertise for the purpose of enhancing their professional development.

By Order of the Secretary of the Army:

DENNIS J. REIMER
General, United States Army
Chief of Staff

Official:

JOEL B. HUDSON

*Administrative Assistant to the
Secretary of the Army*
0011701

Distribution: Special

- 23 THE CASE FOR SQUAD SHARPSHOOTERS**
Lieutenant Colonel Michael R. Harris, U.S. Army, Retired
- 29 TASK FORCE FAITH AT THE CHOSIN RESERVOIR: A Failure of Command, Control, and Communications**
Anthony R. Garrett

DEPARTMENTS

- 1 COMMANDANT'S NOTE**
- 3 INFANTRY NEWS**
- 6 PROFESSIONAL FORUM**
- 6 IS 6mm THE OPTIMUM CALIBER? A Common Cartridge for Rifle and Machinegun
Stanley C. Crist
- 9 PREPARATION OF THE DEFENSE**
Lieutenant Colonel Patrick G. McCarthy
- 12 THE LEADING MANAGER**
Colonel Richard L. Strube, U.S. Army, Retired
- 14 UN COMMAND SECURITY BATTALION—JOINT SECURITY AREA**
Captain Keith A. McKinley
- 16 GROUND LOGPACs FOR LIGHT INFANTRY: Lessons Learned at the JRTC**
Captain Brian Traynor
- 18 FIGHTING IN A FORTIFIED VILLAGE: The Second Chechen War**
Adam Geibel
- 32 TRAINING NOTES**
- 32 TOUGH TRAINING IN TOUGH TIMES: Infantry OCS—1942**
From An *Infantry* Magazine Interview with Colonel Robert B. Nett, U.S. Army, Retired
- 35 THE RIFLE COMPANY: Cohesion through Competition**
Captain Thomas H. Greer
- 38 TRAINING OPPORTUNITIES FOR AIRBORNE BATTALION MEDICAL PLATOONS**
Major Scott T. Glass
- 41 MARKSMANSHIP TRAINING: More than the Basics**
Sergeant First Class Steven D. Miller
- 44 MECHANIZED PLATOON TTPs IN PEACE ENFORCEMENT OPERATIONS**
Lieutenant Kevin J. Perera
- 47 SWAP SHOP: Stabilizing the Long Whip Antenna for the PRC-119**
- 48 INFANTRY CAREER NOTES**
- 49 BOOK REVIEWS**

• **INFANTRY** (ISSN: 0019-9532) is an Army professional bulletin prepared for bimonthly publication by the U.S. Army Infantry School at Building 4, Fort Benning, Georgia. • Although it contains professional information for the Infantryman, the content does not necessarily reflect the official Army position and does not supersede any information presented in other official Army publications. • Unless otherwise stated, the views herein are those of the authors and not necessarily those of the Department of Defense or any element of it. • Official distribution is to infantry and infantry-related units and to appropriate staff agencies and service schools. • Direct communication concerning editorial policies and subscription rates is authorized to Editor, INFANTRY, P.O. Box 52005, Fort Benning, GA 31995-2005. • Telephones: (706) 545-2350 or 545-6951, DSN 835-2350 or 835-6951; e-mail edgertonm@benning.army.mil. • Bulk rate postage paid at Columbus, Georgia and other mailing offices. • **POSTMASTER: Send address changes to INFANTRY, P.O. Box 52005, Fort Benning, GA 31995-2005.** • USPS Publication No. 370630.



Commandant's Note

MAJOR GENERAL JOHN M. Le MOYNE Chief of Infantry

ONE INFANTRY—NOW MORE THAN EVER

There is but one Infantry! The debate surrounding the different types of infantry units has polarized us. It threatens to further divide our branch family at a time when we should be focusing our efforts on the bigger issue of structuring and training to meet the challenges of this century.

The Ranger, airborne, light, air assault, and mechanized elements of our branch all possess unique characteristics dictated by mission requirements, but the purpose of the Infantry (with a capital "I") is still "to close with the enemy by fire and movement to destroy or capture him, or to repel his attack by fire, close combat, and counterattack." Getting to the battlefield is an implied task, and how we get there—by parachute, wheeled or tracked vehicle, on foot or helicopter, or in a Bradley—does not change the fact that we are, and must remain, one Infantry, capable of executing the close-in fight as we have throughout our history. We must keep this in mind even as we examine the structure and missions of the Initial Brigade Combat Team.

Fort Benning recently hosted a conference of former Infantry School Commandants, in which we drew upon their 31 years of experience during discussions of issues affecting our branch. The Commandants unanimously sup-

ported the One Infantry concept, and overwhelmingly concurred with the concept of the Initial Brigade Combat Team. We agreed that we could best achieve a better sense of unity and common purpose within Career Management Field 11 by combining military occupational specialties (MOSs) 11B and 11M, first at Skill Level 1 and eventually at the junior leader level of Skill Level 2 until BNCOC attendance. We are considering including 11H in the future. We see no change at present for MOS 11C because of the unique mission and the technical skills demanded of indirect fire crewmen.

Division and corps commanders were asked to comment on this proposed merger and all but one supported combining at Skill Level 1. Two recommended we take a closer look before extending this to Skill level 2. This has certainly not been finalized yet, and we are prepared to make adjustments as we gain more experience. We value input from the field as we weigh our options on this initiative, so please tell us what you think.

If we are to continue to man the infantry force we need, we must examine ways to increase accessions and reduce the attrition rate among first-term enlistees. The "Buddy Team" concept is one measure that will help

us achieve this goal. We will test this concept for the Army this summer with 1,200 MOS 11M soldiers in 600 two-man teams. The soldiers chosen will be paired up at Fort Benning and will complete one-station unit training (OSUT) together. They will PCS to their first unit and will be assigned to the same company—as a minimum. The goal is to get them in the same squad! In the past, we have relied upon unit/station of choice enlistment options and other incentives to attract soldiers. Now we are taking this one step further by matching each initial entry soldier with a “Buddy” during OSUT. In the event one soldier of the team is unable to complete OSUT, the remaining soldier will be paired with another projected for the same follow-on assignment. This will strengthen the infantry force in several ways: It will increase the number of new enlistments; it will enhance assimilation into the unit in a way our sponsorship programs could not; it will improve unit cohesion; and it will reduce the attrition rate among first-term soldiers. If initial results are successful, all OSUTs will convert to the “Buddy Team” concept.

The Infantry has always taken tremendous pride in the fact that it gets the tough missions. For 225 years it has ensured our freedom while restoring the liberties of others around the world. We have done what was demanded of us, and have been able to speak with one voice on matters that affect our branch. It can be no other way. While technological advances have enabled us to sharpen the specialized capabilities within the types of infan-

try, the mission of the Infantry itself must remain the top consideration in discussions of where the branch is headed. And let us not forget—Hi-Tech advantages aside—the rate of movement of dismounted infantrymen today is essentially the same as it was during the U.S. Civil War. This means that once we dismount, it's a foot soldiers' fight and we must train and retain the best foot soldiers on the battlefield.

As we prepare for the challenges of this century, we must stay focused on the basics. No degree of specialization can replace the soldier who is firmly rooted in the fundamentals of his profession. We need to foster and maintain soldiers' confidence in their leaders, develop the expertise and training at small-unit level to sustain them, and ensure that the infantry squad is manned and resourced at the levels it needs to fight and win. The nine-man infantry squad is absolutely critical to the accomplishment of the Infantry's mission. While some advocate a smaller squad, it is simply not enough in combat. Smaller squads lack adequate firepower and are not robust enough to sustain the casualties of the close-in fight and still accomplish the mission.

These, then, are the challenges we must overcome if the Infantry is to remain the key element of the combined arms team. We must think in terms of one Infantry, speak with one voice, and settle for nothing less than the nine-man infantry squad. When we accomplish this, we can again focus our full attention on the training, sustainment, and survivability issues that will spell success for the Infantry on tomorrow's battlefields.

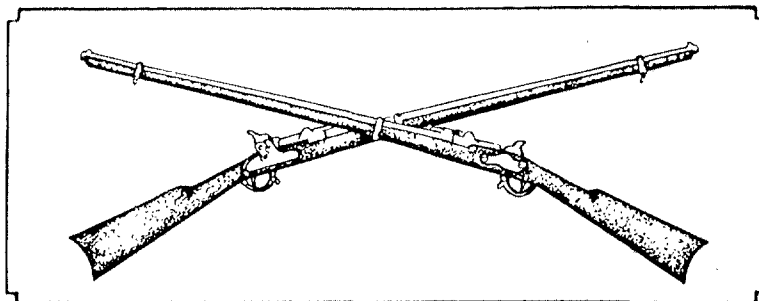

INFANTRY NEWS



A NEW BRADLEY FIGHTING VEHICLE (BFV) exhibit is being developed at the National Infantry Museum, Fort Benning, Georgia. The exhibit is scheduled to open in November 2000. Visitors to the museum will be able to see an M2 Bradley up close, in an outdoor exhibit that features both an M2A1 and an engineering prototype of the M2A3.

The Bradley was developed to accommodate modular improvements. The M2A1, which incorporated the first in a series of improvements, received the improved TOW antitank missile system and a better chemical protection system. The M2A3 prototype features numerous improvements in lethality and survivability.

The indoor BFV exhibit, entitled "Lethal Beyond All Expectations," will be the museum's single largest exhibit.

In addition to equipment and displays, the exhibit will provide a comprehensive overview of the system's development from 1968 to the present, with supporting documentation. It will give visitors insight on the Bradley mission, doctrine, training, and organization. More important, the display will include accounts—by former and current program participants, including combat developers, materiel developers, and industry representatives—of the way the Bradley was developed, tested, fielded, and upgraded over the past 20 years.

The Bradley, as one of the "Big Five" post-Vietnam weapon systems, has had some interesting and unique twists and turns in its development. Following the Vietnam War, the U.S. Army underwent some radical reorganization and significant changes in doctrine, training and tactics. During these critical changes in the U.S. defense posture, and despite a massive build-up of the Soviet Union's armored force, the Army struggled to justify the greatly increased cost associated with replacing its infantry

armored personnel carrier with a much more expensive infantry fighting vehicle. It was against this setting that the Bradley evolved. Visitors will gain rare insight regarding the cost, schedule, and performance trade-offs required during the Bradley acquisition process.

The exhibit will feature newspaper articles, photographs, videos, and displays grouped by events in the program life-cycle. Some of the equipment displayed will include the M242 25mm Bushmaster cannon, M257 smoke grenade launcher, M240C coaxial 7.62 machinegun, M321 5.56mm firing port weapon, training ammunition, infantry squad equipment, TOW missile, M47 Dragon, and SINCGARS (single-channel, ground and airborne radio subsystem).

The U.S. Army Tank-automotive and Armaments Command is seeking Bradley documentation (photos, videotape, significant program documents, newspaper articles) for donation to the exhibit. Of particular interest is information regarding development of the Bradley's developmental predecessor, the MICV (mechanized infantry fighting vehicle) by Pacific Car and Foundry; the three Task Force Reports (Casey, Crizer, and Larkin); the cannon "shoot off" between Hughes Helicopter Company and Ford Aeronautic Corporation; live-fire testing and test reports; and first-hand accounts of the Bradley's performance during Operation *Desert Storm*.

If you have documentation to donate (which will not be returned) or stories you would like to share regarding the development of the Bradley, please forward to: U.S. Army Tank-automotive and Armaments Command; Bldg. 229, SFAE-GCSS-W-BV (ATTN: Diane Urbina); Warren, MI 48397-5000. Email: urbnad@tacom.army.mil

THE CONTINENTAL UNITED STATES (CONUS) Replacement Center (CRC), located at Fort Benning, Georgia, receives and processes individual military personnel, civilians, and units for deployment to and redeployment from theaters of operation. Since December 1995 the CRC has supported operations in Germany, Italy, the United Kingdom, Spain, the Balkan region, and Kuwait, among others.

The core CRC cadre are active duty soldiers, supplemented by U.S. Army Reserve (USAR) units on a rotational basis. The staff provides administrative support and training coordination, while Fort Benning units provide the instruction. The CRC consists of two companies: Company A is responsible for deployment processing and Company B, for redeployment outprocessing.

CRC maintains a website at <http://www-benning.army.mil/fbhome/11th/crc> that shows the week's schedule in addition to providing detailed information on items and paperwork personnel must bring to CRC. The home page also includes a *Frequently Asked Questions* section and useful telephone numbers.

The people processing through the CRC include Active duty soldiers, U.S. Army Reservists and National Guardsmen, Red Cross representatives, technical contractors, civilian linguists, and employees of the Army and Air Force Exchange Service.

Pragmatically, the two days of theater-specific individual readiness training may be the most useful and challenging part of the CRC experience. On the next to last day of Company A's training, the students rotate through six stations (medical evacuation procedures, driving hazards/convoys operations, countermine operations, mine awareness, and force protection skills). On the final day, they rotate through two lanes (force protection and situational awareness) to practice skills learned the

previous day. Although participants undertake and demonstrate tasks they may never do again, the goal is to raise awareness of possible situations and train the proper responses.

The CRC takes its guidance from the theater commanders, and there is no room for exceptions. The deploying individual must document records, make sure they are up to date, and keep copies of everything. And his S-3 or training NCO should be available in case there are questions. If the CRC has any doubt about a person's satisfactory completion of required training, he will go through the scheduled training. This includes medical screening, weapons qualification, driver training, and other standard tasks. Verifying previous training is the individual's responsibility, not the CRC's. If not certified before reporting to CRC, he must be certified before being allowed to move on.

Finally, some *Do's* and *Don'ts* for reporting to CRC. Do arrive by 1900 on the day you are to report. Don't bring a government-provided or personal rental car; they are unauthorized, and you will sign a statement that you are in compliance. Do bring original or certified copies of any documents needed for correcting or reinstating your pay records. Don't bring any personal weapons or ammunition. Do bring your issue eyeglasses and protective mask inserts, along with two sets of ID tags. Do bring your medical and dental records. Don't forget the telephone and fax number for your S-3 or training NCO.

Today's operations require people from the entire Department of Defense and the civilian community. In eight short days, the CRC accomplishes the critical mission of certifying the deployability of these people, providing a baseline of training, and easing the burden of the gaining commanders. (*Submitted by Major Marc B. Carolan, U.S. Army, Europe.*)

TWO NEW INFANTRY SCHOOL field manuals are now available online in the Army Doctrine and Training Digital Library at <http://www.adtdl.army.mil/atdl.html>.

FM 23-90, *Mortars*. This publication prescribes guidance for the leaders and crewmen of mortar squads and platoons. It is concerned with the problems of mortar crew training and presents practical solutions for the timely delivery of accurate mortar fires. It discusses the 60mm mortar (M224), the 81mm mortar (M252), the 4.2-inch mortar (M30), and the 120mm mortar (M120), including nomenclature, sighting, equipment, characteristics, capabilities, ammunition, and maintenance.

FM 23-91, *Mortar Gunnery*. This manual is divided into four parts: Introduction and Fundamentals of Mortar Gunnery, Fire Direction Center, Mortar Ballistic Computer, and M16 and M19 Plotting Boards. It provides guidance for soldiers in MOS 11C and their trainers on the employment of the 60mm, 81mm, 4.2-inch, and 120mm mortars. It discusses practical applications of ballistics and a system that combines the principles, techniques, and procedures that are essential to the delivery of timely and accurate mortar fire.

A NEW VERSION of Training Circular (TC) 23-AIMSS, *Advanced Infantry Marksmanship Strategies and Standards* will soon be available. The manual contains updated 25-meter zero procedures and target offsets for all weapon systems. It provides the latest information on all optics and laser aiming devices, including the PEQ-2A, as well as an updated night training strategy for all small arms and machineguns.

This version of the manual will be available online in the Army Doctrine and Training Digital Library at <http://www.adtdl.army.mil.html>.

THE U.S. ARMY SOUTHERN EUROPEAN Task Force (Airborne), known as SETAF, recently changed the designation of its infantry brigade. There will be no changes to SETAF's headquarters elements, the 22d Area Support Group, or other assigned activities.

The infantry brigade became the 173d Airborne Brigade following an

activation ceremony on 12 June 2000. The soldiers assigned to the brigade and its subordinate units will wear the shoulder patch of the 173d Airborne Brigade. All other soldiers assigned to SETAF will continue to wear the SETAF shoulder patch.

For more information on the 173d Airborne Brigade, visit the SETAF website at www.setaf.army.mil.

THE INFANTRY SCHOOL COURSE Feedback Survey is now available on the Fort Benning web site at <http://www-benning.army.mil>.

If you are an Infantry School graduate, please complete this survey six months after your graduation, and ask your commander or supervisor to complete it as well. All responses will be confidential.

The School's commanders, staff members, and instructors rely on your professional opinion of its effectiveness in producing graduates whose technical, tactical, and leadership skills and physical abilities meet the needs of the 21st century land warrior.

THE LAUNCH GRAPNEL HOOK (LGH) has been developed to help defeat landmine tripwires. Tripwires are commonly used with bounding mines (PROM-1), scatterable mines (BLU-42/B), stake mines (PMR-2A), and directed fragmentation (claymore style) antipersonnel mines, along with hundreds of others. The effective casualty radius of these mines is from 15 to more than 50 meters.

The LGH, was developed under the Soldier Enhancement Program, to meet requirements of light forces executing a deliberate or hasty breach. Approximately 20,000 LGH systems have been produced, with approximately 8,000 fielded to infantry and engineer companies.

The packaged LGH weighs three pounds; the LGH itself weighs only one pound. It has a range of 90 to 100 meters when fired at a 45-degree elevation angle using 5.56mm ball ammunition or the M195 grenade launching blank cartridge (DODAC 1330 G84), fired from

an M16 rifle or M4 carbine.

The recommended firing position is illustrated on the instruction card packaged with the LGH. The system is intended to be fired with the stock of the rifle held under the armpit or, from the prone position, with the butt of the weapon against the ground.

The LGH uses bullet-trap technology designed for one bullet. It can be fired once with 5.56mm ball ammunition. The expected range is between 90 and 100 meters. The M193 or the M855 cartridge may be used to fire the LGH. Firing a second ball round into the LGH creates a fragmentation effect and hence is not recommended.

The LGH is not intended to be fired using tracer ammunition. After being fired using ball ammunition, it can be fired indefinitely using blank ammunition for training. The M195, 5.56mm blank ammunition, launches the LGH approximately 90 to 100 meters. The M200, 5.56mm blank ammunition, launches it 20 to 25 meters and is suitable for training. Of the 3,300 launches during testing in 1995, there was no evidence of either degradation or damage to the system or the test weapon.

To achieve the greatest effectiveness for the LGH system, the firer must control the retrieval speed. Army tests have shown that pulling the hook back in a slow, controlled manner increases the system's ability to counter tripwires from 75 percent to 94 percent. The LGH was found to be approximately 90 percent effective in several environments, including tall grass, rocky soil, plowed earth, woodline vegetation, and grass less than a foot high.

Reusing the system's retrieval line for training is not recommended, but a training bag is available that has a line especially designed for multiple firings. At least one NATO country uses this bag as the combat system.

The NSNs are 1095-01-412-4150 for the LGH and 1095-01-413-9232 for the training bag with reusable line. The cost for either version is less than \$100. Delivery time is approximately one week in the continental United States and two weeks elsewhere. The DO-DAC for M195, 5.56 NATO blank ammunition is 1330 G84.

The point of contact at PM-MCD is Mr. Brian Green at DSN 654-1968, commercial (703) 704-1968, Fax (703) 704-1969, email bgreen@nvl.army.mil. *(Submitted by Major Mark Stephens, Assistant Project Manager for Countermeasure Systems.)*

TOP-OF-THE-LINE WEAPONS and items of equipment were tested recently at Fort Drum as a part of the Military Operations in Urban Terrain (MOUT) Advanced Concept Technology Demonstration (ACTD). U.S. Army soldiers and U.S. Marine Corps personnel participated in the tests.

The MOUT ACTD is set up to improve the survivability of soldiers in an urban environment. Once the soldiers have trained with it, it can be fielded and used at Joint Readiness Training Center (JRTC) at Fort Polk.

The soldiers and marines were asked to offer suggestions for improving on the equipment, and modifications were made to the equipment after every test run.

Several innovations were tested for soldier approval:

Explosive cutting tape (ECT). The ECT, which looks like a honey bun when placed on a wall, is a flexible, rope-like explosive used to blast a man-size hole through a brick wall. It is used in 12-to-20-foot sections that are mounted by tape or another adhesive on its flat bottom surface. A styrofoam-like material surrounds the copper core that contains the explosive. A simple fuse and detonator are used to ignite the device, which produces an explosion focused in the direction of its bottom surface. The focused explosion eliminates possible debris from the blast that could harm friendly troops.

The breacher's explosive access selectable tool (BEAST). This tool, which resembles a sleeping bag or a blanket at first glance, is used to blast a man-size hole into a section of brick wall, ceiling, or roof. The two-by-five-foot device has a diamond-shaped explosive embedded in its fabric. Tape or another adhesive is used to place it on its target, and a standard fuse and detonator are used to ignite it.

Rifle-launched entry munition.

This device, which looks like a fencing sword, is attached to and fired from the barrel of an M16 rifle or M4 carbine. It is designed to eliminate the doors or windows of a building from a distance of 10 to 30 meters.

New collapsible ladders. The more lightweight, compact ladders enable soldiers to get as high as the third floor of a building.

The new quick stepladder, made of a lightweight aluminum alloy, can be employed in a matter of seconds. The two-by-three-foot package attached to a rucksack can extend up to 14 feet.

The sectional light modular ladder extends up to 15 feet, and with a second segment attached extends to 30 feet, allowing insertion into a third-story window or entry through the roof of a two-story building. This ladder can be carried in a man-pack.

Hooligan Tool. Once in close quarters and tight spaces inside a building, soldiers use this mechanical device to defeat doors, locks, and windows. It is wedged into the door or window frame and pounded with a hammer to gain forced entry. The squad-level tool is carried on a squad member's rucksack where it is easily accessible.

Stun Grenade. Once the door or window is open, this small, handheld device is used to set off a loud bang and then a bright flash to disorient enemies.

Other advanced technology items include a newer, lighter body armor to improve soldiers' protection against rifle fire, new elbow and knee pads to stave off pain when soldiers crawl on cement or other tough surfaces, and the new Tuff Cuffs, which can be applied to prevent further resistance once an enemy has been subdued.

This equipment should be issued to all infantry units in the 10th Mountain Division in time for the battalion- and brigade-level exercises scheduled to take place in preparation for the Advanced Warfighting Experiment this fall. After the equipment is tested during the AWE, feedback from soldiers will determine whether it will be accepted for issue on a wider basis. *(This item was provided by the Public Affairs Office, 10th Mountain Division.)*

PROFESSIONAL FORUM



Is 6mm the Optimum Caliber? A Common Cartridge for Rifle and Machinegun

STANLEY C. CRIST

During World War II, the German army developed the first assault rifle to be issued on a large scale. Originally fielded as the MP43, the rifle was later redesignated the StG44, reflecting a change in nomenclature from machine pistol to *Sturmgewehr*, which loosely translates in English as *assault rifle*. The StG44 was chambered for the 7.92x33mm round, a cartridge with less power and more compact size than that fired by the standard infantry rifle. Because studies had indicated that most infantry combat occurred at relatively short engagement distances, the Wehrmacht deemed it unnecessary and wasteful to continue using the heavier, bulkier ammunition.

In marked contrast, Germany's paratroopers—who were a component of the air force, not the army—undertook the development of the FG42, a select-fire combat rifle that used the full-power 7.92x57mm service cartridge. Because they had found themselves outranged by British riflemen and machinegunners during the initial stages of the 1941 airborne assault on Crete, the German paratroopers reasoned that it was distinctly better to have long-range capability and not need it than to need it desperately and not have it.

After World War II, these opposing philosophies appeared again, during the effort by NATO countries to adopt a standard rifle cartridge. Britain led one

faction, which was in favor of selecting the British 7x43mm assault rifle round. On the other side was the U.S. Army, which wanted to retain the range and power of the .30 caliber cartridge then in use. Needless to say, as the most powerful and influential member of NATO at the time, the United States prevailed, and the 7.62x51mm round became NATO-standard shortly after the end of the Korean War.

Another reason the United States preferred full-power ammunition was to simplify logistics. The Army had fought World War II and the Korean

conflict with a wide variety of small arms that were chambered for two completely different calibers. The standard .30 caliber cartridge was used in the M1903 Springfield, 1917 U.S. Enfield, and M1 Garand rifles, M1918A2 Browning automatic rifles, M1917A1 (water-cooled) heavy machineguns, and M1919A4/A6 (air-cooled) light machineguns, while the shorter and less potent .30 Carbine round was required for M1, M1A1, M2, and M3 carbines. The Army wanted to replace this menagerie with only two basic weapons—a rifle and a general purpose machine-

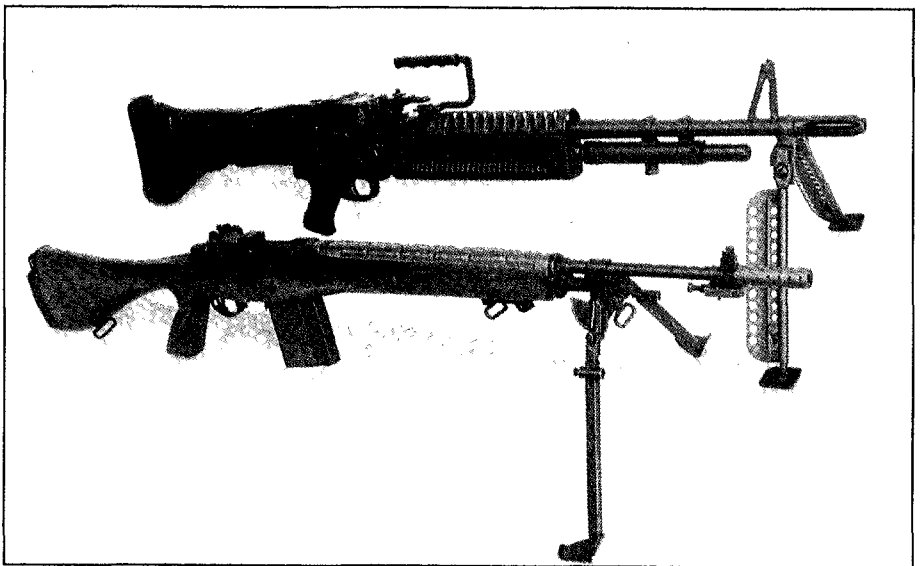

After World War II, the U.S. Army adopted a one-caliber, two-weapon philosophy, developing the M60 general purpose machinegun and the M14 rifle to replace the array of small arms and two calibers of ammunition then in service. From the logistical viewpoint, this was a good concept, but circumstances prevented its full implementation.

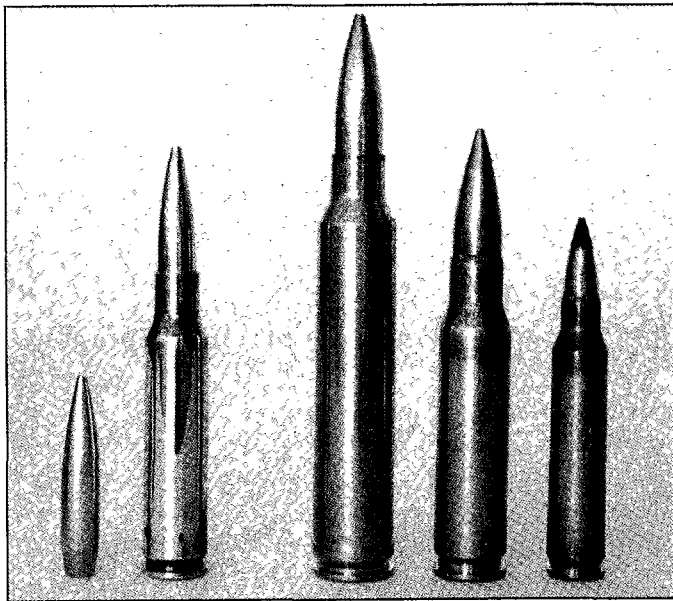

The conceptual 6mm Optimum cartridge (left) would have the velocity and trajectory of the .300 Winchester Magnum, the penetration and tracer performance of 7.62 NATO, in a format almost as compact and lightweight as 5.56 NATO.

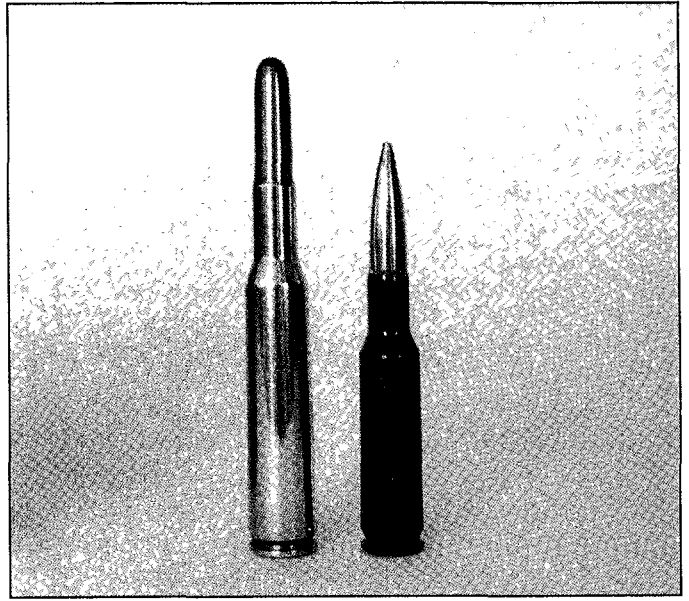

The 6mm Navy round (left) was adopted in 1895 for use by the Marines and naval landing parties. In the 1970s, the Army developed the 6mm XM732 cartridge (right) for the squad automatic weapon program.

gun—and one caliber of ammunition.

This was a very worthwhile objective, but it was doomed to failure. The substantial recoil generated by the 7.62mm NATO round made the rifle difficult to control when fired on full-automatic, even in the M14A1 automatic rifle version. In addition, by insisting on a full-power .30 caliber cartridge, the Army ensured that the M14—which was originally supposed to be a “light rifle”—would be almost as heavy as its predecessor.

The weight factor, perhaps more than any other, sealed the M14’s fate. In the late 1950s, the Air Force was offered the M14 as a replacement for its aging, but delightfully lightweight, M1 and M2 carbines. The offer was declined, and a few years later the Air Force purchased the ArmaLite AR-15, a rifle that was a little heavier than the obsolescent carbines then in its inventory. Not long after that, the Office of the Secretary of Defense also directed the Army to buy the AR-15 (subsequently known as the M16), and discontinue the acquisition of M14 rifles, thereby forcing the Army back into a two-caliber system.

Could the Army have taken a course that would have avoided the return to a two-caliber system? Clearly, not by sticking to the demand for a full-power 7.62mm round. As the British had correctly pointed out, the power of the

ammunition determines the size and weight of both the cartridge and the weapon in which it is fired. Nor could the Army have avoided this outcome by adopting the British 7x43mm caliber. Every nation that has issued assault rifles to its armed forces has found it necessary to retain a full-power cartridge in the inventory for use in machineguns and sniper rifles.

Considering the technical and political difficulties involved, is a one-caliber family of small arms an achievable goal? Answering that question requires a look at the desired characteristics of the infantry rifle, the machinegun, and the sniper rifle.

For the infantry rifle, the weapon and ammunition should weigh as little as possible, consistent with a maximum

effective range of at least 500 meters.

For the machinegun, the same weight considerations apply but with a maximum effective range of 1100-1200 meters. Ball ammunition should be able to defeat “hard” targets at least as well as the 7.62 NATO round. Tracers should be visible out to more than 800 meters during daylight.

For the sniper rifle, the weight of weapon and ammunition is not as important as accuracy and effective range. Maximum effective range should be greater than 800 meters, with the flattest possible trajectory.

Of these characteristics, the snipers’ need for a flat trajectory and short time-of-flight to the target would seem to be the most critical, so this would be the logical start point in developing the

BALLISTICS DATA				
Caliber	5.56 NATO	6mm Optimum	7.62 NATO	.300 Win Mag
Bullet weight (grains)	62	100	147	190
Muzzle velocity (fps)	3100	2900	2800	3000
Muzzle energy (ft.-lbs.)	1323	1867	2559	3796
Velocity @ 1200m (fps)	913	1149	990	1214
Energy @ 1200m (ft.-lbs.)	115	293	320	622
Flight time to 1200m (sec)	2.63	2.21	2.54	2.10
Deflection @ 1200m in 10 mph wind (inches)	240	151	200	139
Maximum trajectory (inches)	365	244	332	218
Note that even with a conservative estimate for the muzzle velocity of the 6mm Optimum cartridge, computed data for 1200-meter velocity, flight time, wind deflection, and trajectory height are greatly superior to both 5.56 and 7.62 NATO rounds.				

optimum small arms cartridge. In order to achieve a flat trajectory, the bullet must have a very streamlined shape and be propelled at high velocity. The shape of a bullet can be described in terms of its ballistic coefficient (BC)—the higher the BC, the more streamlined the projectile and the flatter the trajectory.

For instance, the 168-grain bullet in 7.62mm M852 Match ammunition has a BC of 0.48, which is well below that of the 190-grain projectile (BC = 0.54) used in the .300 Winchester Magnum cartridge. Because the M852 round has a rather low muzzle velocity (2600 feet per second, when fired from the M24 sniper weapon), the trajectory is high, the time-of-flight is long, and the maximum effective range is no more than 800 meters. On the other hand, the faster muzzle velocity (3,000 feet per second) and superior bullet shape of the .300 Winchester Magnum result in an extremely flat trajectory, a very short flight time, and a maximum effective range of about 1,000 meters.

Obviously, it would be quite desirable to incorporate the described characteristics of the .300 Winchester Magnum into the optimum cartridge; doing so would mandate the use of a projectile with a ballistic coefficient as close to 0.54 as is practical. In order to achieve the penetration capabilities the machinegun needs, bullet weight would have to be substantially heavier than the 62-grain projectile of 5.56mm M855 Ball, but much lighter than the 147-grain service bullet now in 7.62mm M80 Ball. A weight of 100 grains seems like a reasonable, if intuitive, compromise—light enough to be pushed at or near the desired velocity, but without the bone-jarring recoil of the powerful .300 Magnum.

Without resorting to the use of exotic, expensive metals such as tungsten or depleted uranium, a 100-grain bullet with a BC of approximately 0.54 would have to be made in caliber 6mm. Larger diameter projectiles of the same weight have inadequate BCs, while technical limitations prohibit the use of such heavy bullets in calibers smaller than 6mm. A 100-grain, 6mm projectile of conventional construction (lead

AUTHOR'S REQUEST: Frankford Arsenal is said to have conducted penetration tests (probably around 1974) of the 6mm SAW ammunition, comparing it to 7.62mm NATO and possibly 5.56mm. If any *INFANTRY* reader knows where a copy of this report can be obtained, I would like very much to hear from you. Please write c/o *INFANTRY*, P.O. Box 52005, Fort Benning, GA 31995-2005.

core and cupro-nickel) that is launched at close to 3000 feet per second ought to have penetration capability at least as good as that of 7.62 NATO.

Another benefit of 6mm ammunition is improved tracer performance. The 6mm XM734 tracer round, developed in the 1970s at Frankford Arsenal, produced a trace that was visible in daylight to a range of 1000 meters. That is at least 25 percent better than 5.56mm tracers, which are difficult to observe at 800 meters during the day.

The cartridge case for the "6mm Optimum" would have to be larger than that of 5.56 NATO but smaller than 7.62 NATO. With a 100-grain bullet, the loaded round would be midway in weight and bulk, compared to the M855 and M80 cartridges. To keep cartridge volume to a minimum, muzzle velocity might have to be limited to perhaps 2,900-2,950 feet per second, but this should still be fast enough to produce exceptional performance from the proposed round. In essence, it would be a magnum version of the 6mm XM732 Ball round made for the squad automatic weapon (SAW) program in the 1970s, which propelled a 105-grain bullet at 2500 feet per second.

The 6mm SAW was a step in the right direction, but it came too late. The 7.62mm and 5.56mm calibers were already in service, and leaders did not want to complicate the logistical situation further by adopting a third caliber. Accordingly, the squad automatic weapon was then developed to use 5.56mm ammunition.

The Army had a logistically sound idea in trying to create a small arms system of one caliber and two weapons. Unfortunately, the wrong caliber was chosen, and a golden opportunity was

lost. By insisting on developing the best possible 7.62mm cartridge instead of the best possible cartridge regardless of caliber, today's logistical situation is at least as complex as that of the 1940s, with 5.56mm for the M16A2 rifle, the M4 and M4A1 carbines, and the M249 light machinegun, and 7.62mm for the M60 and M240B/G medium machineguns and the M21 and M24 sniper rifles.

One caliber—the 6mm Optimum—could do it all. A weapon sending a 100-grain, very low-drag bullet downrange at over 2900 feet per second would give snipers the flat trajectory of the .300 Winchester Magnum. And it would give machinegunners the penetration potential and tracer capability of 7.62 NATO, thereby permitting the development of an infantry machinegun light enough to replace both the 7.62mm medium machinegun and the 5.56mm squad automatic weapon. The 6mm Optimum—being a compact, lightweight cartridge, with low recoil impulse—should also allow the creation of a combat rifle that is little or no heavier than the M16A2.

If the 21st Century should bring about a renewed quest for a lightweight infantry rifle and machinegun chambered for the same caliber, there is only one choice that makes sense. The 6mm Optimum combines the best features of several existing cartridges into a compact, lightweight round that should be capable of all around performance unequalled by any other caliber. Let it be the one for all.

Note that even with a conservative estimate for the muzzle velocity of the 6mm Optimum cartridge, computed data for 1200-meter velocity, flight time, wind deflection, and trajectory height are greatly superior to both 5.56 and 7.62 NATO rounds.

Stanley C. Crist served as a tank commander, tank platoon sergeant, training NCO, and scout section leader in the 3d Battalion, 185th Armor. He has had numerous articles about infantry weapons published in *Infantry* and other defense-related publications. He is currently a consultant and writer, specializing in the testing and evaluation of small arms and ammunition.

Preparation of the Defense

LIEUTENANT COLONEL PATRICK G. McCARTHY

During the preparation of the defense, time management is a critical task. Often, units receive the order to transition to the defense and, before they realize it, the available time slips away and their companies and platoons rush to prepare their positions. Time management seriously affects the success of the unit conducting the operation.

There are three things commanders can do to make effective use of the time available:

- Occupy the defense as early as possible.
- Follow a methodical *planning priority of work* during concept development.
- Integrate the *preparation priority of work* into the time schedule.

Early occupation is critical because the soldiers must have enough time to effectively execute the preparation priority of work. The commander's first step in early occupation is to define what tasks his subordinate units must accomplish before they can report that they have occupied the defense. Depending on which manual is used as a reference, this task is not well defined in doctrine. As a minimum, the unit should establish security and communications, reconnoiter the defensive sector or battle position, and position crew-served weapons and assign sectors of fire to complete occupation. The commander may also want to have final protective fires (FPFs) planned, hasty positions prepared, or critical obstacles emplaced before reporting occupation. He should establish these tasks in the unit standing operating procedures (SOPs).

The next step is to determine when his units must occupy the defense in

order to have enough time to complete the *preparation priority of work* before the *defend by* time. Many units miss this step. They are lulled into a sense of security in the tactical decision making process using the one-third/two-thirds rule by focusing on the *defend NLT* (not later than) time. It appears that they have plenty of time to plan, move, and prepare logically and sequentially. The commander has several options in determining the *occupation NLT* time (Figure 1).

First, in analyzing the factors of METT-T (mission, enemy, terrain, troops, and time), the commander can determine how long he thinks it will take his unit—on the basis of its training level, the terrain, and other factors of mission analysis—to be prepared to defend by the NLT time. For instance, in a typical 72-hour defense planning time schedule, he might estimate that he needs 36 hours. He then subtracts this amount of time from the time available and uses the one-third/two-thirds rule to develop his planning schedule for the time remaining before he must report he has occupied the position.

A second way is to take one-third of the time available—24 hours in this case—to establish the occupation time (D-24) and then use the one-third/two-thirds rule on the time available before the occupation time to establish his planning time line. He could also use the one-fifth/four-fifths rule in the defense instead. The amount of daylight remaining is also a key consideration in establishing the occupation time, since it is difficult to reconnoiter and position weapons and obstacles in the dark.

In the normal one-third/two-thirds technique, a unit often fritters away the

available time and leaves very little for preparation. When it is clear that time is critical, the unit has to rush to occupy the defense immediately after the company order. The brigade and battalion staffs begin to pressure the companies to move into position, receive handover of obstacles, identify Class IV and V logistical release points, position forces to counter divisional and regimental reconnaissance, submit and adjust FPF grids, backbrief, rehearse, and so on. As a result, the company commander's focus quickly dissipates. Company, platoon, and squad level troop leading procedures suffer. Reconnaissance, force protection, and weapon positioning are poor. Obstacles are not integrated with the company scheme of maneuver. Engineer equipment lies idle. Coordination suffers. Force protection takes a back seat to position preparation. Units focus on positions with overhead cover and sector sketches instead of on reconnaissance and security (R&S) patrols, local security, protection of engineer assets in their sector, passive air defense, camouflage and concealment, or protective obstacles.

The obvious advantages of the three options are that they allow the soldiers and junior leaders 36, 24, and 21 hours, respectively, to prepare the defense. These techniques also increase the time available to emplace tactical obstacles and get leaders on the defensible terrain to confirm the tentative plan, coordinate obstacle positioning and handoff, backbrief on the ground, receive Class IV and V, etc. The disadvantage is the reduced planning time at battalion and brigade level, but this is not necessarily bad news. It may be better to give subordinates a hasty plan and get them on

the terrain to confirm and refine that plan through reconnaissance and the backbrief and rehearsal process. Moving units early into the planned defensive sector or battle position provides security for continued reconnaissance in that area as well.

The early occupation of the defense can help solve numerous problems in executing the *preparation priorities of work* before the *defend by time*. But early occupation without a focus is not enough. The unit develops that focus through a methodical approach to the planning process, which should start as soon as the unit receives a warning order. The critical steps between the mission analysis and a solid concept are to determine avenues of approach, identify engagement areas, position antiarmor weapons and tactical obstacles to support the engagement areas, position infantry with protective obstacles oriented against dismounted avenues of approach, likely dismount points and overwatching tactical obstacles, and then integrate fire support, command and control, intelligence, combat service support, and air defense to support the scheme of maneuver. This methodical approach is essentially a *planning priority of work* for concept development.

The order in which the commander and staff apply this model depends, to a great extent, on the unit's assigned task and purpose. Since the defense seeks to wrest the initiative from the attacker, the first step must be to analyze the enemy's avenues of approach and how he will use them. If the unit's task and purpose focus on the enemy—delay, disrupt, or attrit the enemy—the second step should be to determine where it can best kill the enemy and designate an engagement area. Following this, they should position antiarmor weapons to kill the enemy in the engagement area and then position obstacles to fix or disrupt him. But if the focus is on the terrain—retain terrain, turn, block, or channel the enemy—the second step must be to position tactical obstacles to block or turn the enemy and then determine engagement areas and antiarmor weapon positions that overwatch and protect those obstacles.

72-HOUR DEFENSE PLANNING TIME SCHEDULE				
EVENT	NORMAL TO DEFEND TIME	OPTION 1 COMMANDER ESTIMATE	OPTION 2 1/3 OF TIME FOR PREPARATION	OPTION 3 1/5-4/5 RULE
DIVISION ORDER BDE TLP	D-72 24 HRS	D-72 12 HRS	D-72 16 HRS	D-72 14 HRS
BRIGADE ORDER BN TLP	D-48 16 HRS	D-60 8 HRS	D-60 11 HRS	D-58 11 HRS
BATTALION ORDER CO TLP	D-32 10 HRS	D-52 5 HRS	D-45 7 HRS	D-47 9 HRS
COMPANY ORDER PLT TLP	D-22 7 HRS	D-47 4 HRS	D-38 5 HRS	D-38 7 HRS
PLATOON ORDER SQD TLP	D-15 5 HRS	D-43 2 HRS	D-33 3 HRS	D-31 6 HRS
SQD ORDER MOVE TO/RECON	D-10 ASAP	D-41 5 HRS	D-30 6 HRS	D-25 5 HRS
OCCUPY POSITIONS PREPARE	ASAP <10 HRS	D-36 36 HRS	D-24 24 HRS	D-21 21 HRS
DEFEND NLT TIME	D-HR			

Figure 1

STAFF PLANNING PRIORITY OF WORK		
TASK	RETAIN/BLOCK/CANALIZE	DELAY/DESTROY/ATTRIT
OBSTACLE INTENT	BLOCK/TURN	FIX/DISRUPT
Step 1	DETERMINE AVENUES OF APPROACH	
	<ul style="list-style-type: none"> - Go/Slow Go/No Go Terrain - Mobility corridors - Situation template 	
Step 2	POSITION TACTICAL OBSTACLES	DETERMINE ENGAGEMENT AREAS
Step 3	DETERMINE ENGAGEMENT AREAS (to protect obstacles)	POSITION ANTITANK WEAPONS
Step 4	POSITION ANTITANK WEAPONS	POSITION TACTICAL OBSTACLES (to support engagement areas)
Step 5	POSITION INFANTRY	
	<ul style="list-style-type: none"> - Determine dismounted avenues of approach to obstacles and AT weapons - Determine possible dismounted assault positions - Determine possible mounted dismount points - Determine dismounted engagement areas - Position crew-served weapons - Position protective obstacles to support dismounted engagement areas - Position squads to protect crew-served weapons and obstacles 	
Step 6	INTEGRATE THE FIRE SUPPORT PLAN	
	<ul style="list-style-type: none"> - Tactical obstacles - Infantry positions - Engagement areas 	<ul style="list-style-type: none"> - Engagement areas - Tactical obstacles - Infantry positions
Step 7	INTEGRATE COMMAND, CONTROL, COMMUNICATIONS, AND INTELLIGENCE	
	<ul style="list-style-type: none"> - Decision support template - Reconnaissance and security plan - Synchronization matrices - Engagement priorities 	
Step 8	INTEGRATE AIR DEFENSE AND COMBAT SERVICE SUPPORT	

Figure 2

In both instances, the third step is to position infantry to protect the antiarmor weapons and obstacles. Then the staff must integrate the plans for fire support, intelligence collection, and command and control to support the

scheme of maneuver. In this step, the staff must focus the unit's combat multipliers against the biggest threat at the decisive point. In the enemy-focused task and purpose, these plans focus assets to detect, deliver, assess, and direct

DEFENSE PREPARATION PRIORITY OF WORK (Based on FM 7-10)	
TERRAIN ORIENTED	ENEMY ORIENTED
ESTABLISH R&S OPERATIONS	
Security and Communications	
Site tactical obstacles	Position AT weapons
Position AT weapons	Position crew-served weapons
Position crew-served weapons	Site tactical obstacles
Assign Sectors of Fire	
Position Other Assets	
Designate FPLs/FPFs	
Emplace critical tactical obstacles	Clear fields of fire
Clear fields of fire	Emplace critical tactical obstacles
Prepare Range Cards	
OCCUPATION TIME (BEFORE DIVISION RECON IF POSSIBLE)	
Prepare Hasty Fighting Positions	
Emplace tactical obstacles	Direct fire control measures
- Blocking	Adjust indirect fires
- Turning	Emplace tactical obstacles
- Fixing	- Blocking
- Disrupting	- Fixing
- Direct fire control measures	- Turning
- Adjust indirect fires	- Disrupting
Prepare armpit deep fighting positions	
Designate alternate/supplementary positions	
Establish wire communications	
Emplace protective obstacles	
Overhead cover and camouflage	
RAG WITHIN RANGE OF DEFENSIVE POSITIONS	
Recon routes to alternate/supplementary positions	
Prepare hasty alternate/supplementary positions	
Rehearse contingencies	
Establish sleep/rest plan	
DEFEND NLT TIME	
Stockpile ammunition, food, and water	
Dig trenches between positions	
Alternate/supplementary positions prepared	
REGIMENTAL RECON	
Go to MOPP 2	
ENEMY CHEMICAL ATTACK	
R&S possible enemy dismounted avenues of approach	
DISMOUNTED INFILTRATION	
R&S possible enemy assault positions	
ENEMY PREP FIRES DISMOUNTED ATTACK	
R&S possible enemy mounted avenues	
Local counterattack	
MOUNTED ATTACK	
Support counterattack	

Figure 3

combat power against mounted forces in the engagement area and, secondarily, to protect the killers from the dismounted threat. In the terrain-oriented focus, the unit focuses these assets to prevent the breach of obstacles. The primary focus is on the threats that can unhinge the obstacle plan, dismounted infantry and engineer equipment, and then secondarily to reduce the enemy's mounted forces enough to convince the

enemy to go where the commander wants him to go. The final steps are to integrate combat service support and air defense plans with the scheme of maneuver (see Figure 2).

The final method of saving time in the defense is to integrate the preparation priority of work into the unit time schedule. The commander must look at the time between occupation and the defend NLT time. The actual priority of

task accomplishment will vary with anticipated enemy actions. If the enemy's regimental artillery group (RAG) is within range and air parity exists, overhead cover and MOPP-2 are more important than if the RAG will not be in range for 24 hours and the unit has air superiority. The level of preparation needed is based on the way the commander visualizes the battle. For instance, if he believes that most of his units will have to occupy alternate or supplementary positions before the enemy arrives in force, then he may choose to have hasty positions in alternate and supplementary positions instead of simply requiring reconned routes to designated positions using natural cover only.

Once the commander determines these two things, the staff must allocate time to accomplish these critical tasks and establish NLT times within the preparation priority of work for each of them. These times should be established in relation to the enemy's anticipated actions. This will allow the staff to track the preparation of the defense and recommend to the commander when to shift assets if a segment of the defense is not prepared in a timely manner. Figure 3 shows an example, using a timeline at company level to achieve this reallocation of assets.

The defense is extremely difficult to execute because of the enormous number of tasks that must be done in preparation. Without a detailed schedule for planning and preparation, either in the unit SOP or as a result of mission analysis, no unit can effectively prepare the defense to achieve the commander's intent. These three suggestions can help a unit manage its time. To improve time management, commanders and staffs need only to adapt these models to the conditions of their unit's particular defensive operation.

Lieutenant Colonel Patrick G. McCarthy served as a battalion S-3 in the 504th Infantry and as operations group S-3, observer-controller and command group executive officer at the Joint Readiness Training Center. He also served as a company commander and staff officer in the 10th Mountain Division. He is a 1980 ROTC graduate of Ripon College in Wisconsin.

The Leading Manager

COLONEL RICHARD L. STRUBE, JR., U.S. Army, Retired

Are you a leader, or are you a manager? This question has rolled around in the minds of Army officers and non-commissioned officers for years, yet there is still no clear-cut answer. Sometimes the answer is *almost* found in one's job title: platoon leader, squad leader, company commander, team leader. But other titles give virtually no clue: platoon sergeant, first sergeant, division signal officer. Certainly most would agree that a title containing the term "commander" connotes leadership, yet commanders at all levels are evaluated on management skills and measures as much as on leadership skills—and sometimes perhaps more on management. So, do these terms mean the same and are they therefore interchangeable? What are the distinctions, and where are they found?

There are some clues in the professional development process, especially as it relates to the Officer and NCO Education Systems. There are the Primary Leadership Development Course, the Command and General Staff Officers Course, the Army Logistics Management College, and even an Organizational Leadership for Executives Course. But there are also the Basic NCO Course, the Advanced NCO Course, the Officer Advanced Courses, the Combined Arms and Services Staff School, and the Army War College. None of those use either *management* or *leadership* in their titles. You are taught to be an "advanced NCO" or an "advanced officer," whatever those are.

It is almost as though there is a deliberate effort to keep the waters muddy on

these terms. Interestingly enough, all these schools, and others, teach *both* management skills and leadership skills. The Army's extensive formal schools system begs another different but related question: Are leaders born, or are they taught? What about managers? Some will argue that there are several core, basic leadership skills that seem to



be part of one's personality, in the genes so to speak. Leadership training serves to hone those skills and develop others, but it is difficult to fully assess what it is that marks "natural" leaders.

Most would probably agree that management skills are easier to teach, that they lend themselves more to an academic discipline, and that it is possible to train a poor manager to be a much more effective manager. That is not necessarily true of leadership, however. But some strong leaders may never be

effective managers, and there is some evidence that they may not achieve the same career success as those who are proven managers.

It can be argued that the higher a soldier's rank, the more important management skills are to his career. This may be because leadership is more closely related to the personal interactions between leaders and their soldiers, and the more senior the person, the less opportunity there may be to demonstrate leadership. An interesting variant on this, however, is what I call Leadership Tiering. A division commander may be seen as a strong leader to the brigade and battalion commanders—those subordinates who operate within the senior "tier" of the division—but his impact may be almost negligible to those at lower tiers. Most privates in a rifle company have no concept that the reason they are winning the fight is that their commanding general is providing the tools and conditions required for success. To them they are winning because they have a great *company* commander and an awesome platoon sergeant and because they are confident in their training. The fact that the commanding general managed a superb training program, or that the division support commander managed a superb logistics and maintenance program, has no relevance. At the battalion level, the tier is different, and a company commander who cannot manage a good company supply program may still be seen as a superb leader by soldiers who look to him for other things.

When a unit is in the attack and is

meeting strong resistance, it is leadership that gets it onto the objective. When the unit is consolidating and rearming and repairing vehicles and eating meals, it is management that makes those essentials happen. Of course, the S-4 may have had to fight a battle to get the logistics package to the front, and he may have had to exert strong leadership to get tired and wounded and hungry soldiers to overcome a number of obstacles in getting the trains forward.

Thus it seems that it may be virtually impossible to separate leadership from management. One way to view it may be that planning is management and execution is leadership, but even that definition does not cover all the nuances. The soldiers in a unit that has conducted a successful attack see their leadership tier as perhaps one or two echelons above them—maybe to the battalion commander. Instinctively, they know that they were led to victory by an inspiring, up-front captain or lieutenant colonel who was leading them to defeat the enemy. They know that after they win the fight and seize the objective the wounded will be evacuated, they will get more ammunition, their equipment will be repaired, they will eat, and they will get some rest. They know this because their leader has told them he will do those things. The fact that it is the management of combat service support actions that makes those things happen has no relevance in their life at that moment. The battalion and brigade commanders feel the same confidence that the division commander will provide the resources they need to continue the battle because they know he is a superb manager of division operations.

While leadership may be viewed by tiers, management is not so position dependent. Soldiers in a signal platoon or in a truck company may not fully understand what management is and the effect it has on them and their ability to perform their jobs, but they know that a lot of what happens around them is the result of management practices. They know that every soldier in the unit has housing, receives medical care, and gets paid regularly. They know that spare parts are provided, ammunition is is-

sued as needed, and they will rotate cycles of intensive training with cycles of “housekeeping” activities. That food is available in the dining facility is a given—it is management that provides it. It is leadership that brings hot coffee and soup to the vehicle wash rack at 2300.

The Army manages a complex and sophisticated retention program designed to make sure the force gets the right soldiers with the right skills at the right grades. The unit with good leadership re-enlists those soldiers, achieving the management goals.

It is apparent that while leadership and management have different definitions in the dictionary, they are intertwined in such a manner that a successful, effective leader who both accomplishes his missions and takes care of his soldiers must use both. A good

That food is available in the dining facility is a given—it is management that provides it. It is leadership that brings hot coffee and soup to the vehicle wash rack at 2300.

commander manages an effective safety program. A good leader ensures that his soldiers are not hurt in accidents. Analyzing accident data, writing a safety policy, and inspecting for hazardous conditions are part of safety management. Enforcing the policy, training the soldiers, and eliminating the hazardous condition are part of leadership. Strong leadership coupled with sound management will almost certainly lead to better units. Commanders and leaders at all levels need to do both in order to maximize their influence.

As a soldier matures and develops and progresses up the ranks, the differences between leadership and management will become less clear; the gray areas will overlap the clear distinctions between them that may exist at certain times or under certain circumstances. There is more gray at the division tier than at the battalion tier. The more successful leaders may be those who are

able to understand the distinctions and then provide either more management or more leadership in a particular situation and environment. A good manager can write superb plans and policies, but without proper leadership those plans will remain ideas and concepts on paper, not actions taken. The Chief of Staff of the Army is certainly a leader, but it is his management skills that enable him to perform his duties effectively. General George Patton was certainly a superb manager, but he is remembered for his powerful leadership in war.

The debate (if one considers the topic debatable) will almost certainly continue because it is virtually impossible to put either leadership or management into a neat package and call it a “stand-alone” process. The two are essentially inseparable. Leaders will always have to manage, and managers will frequently be called upon to lead. The distinctions between the two may be more pronounced at the junior officer and NCO levels, at the lower echelon tiers of an organization, because resolving the issues and events commonly encountered there generally requires more direct interaction between leader and subordinate. Squad and platoon leaders need to focus on doing those things that lead to mission accomplishment while providing for the welfare of their soldiers. Strong management skills are more essential to field grade officers and senior NCOs than to company grade officers and middle-grade NCOs. The very best infantry platoon sergeants I ever observed considered themselves leaders, and they invested all of their time and professionalism in leading. However one wants to define these terms, there can be no real debate that they must be used simultaneously in order for commanders, and their units, to be the best they can be.

Colonel Richard L. Strube, Jr., was commissioned through Infantry Officer Candidate School at Fort Benning and served in a variety of command, staff, and leadership positions throughout his 27-year career. He was assigned to the office of an Assistant Secretary of the Army before his retirement in 1995 and is now a management consultant.

UN Command Security Battalion

Joint Security Area

CAPTAIN KEITH A. MCKINLEY

When I learned I was being assigned to the Republic of Korea, I assumed I would be serving in an infantry battalion in the 2d Infantry Division. Instead, I was assigned to the United Nations Command Security Battalion-Joint Security Area (UNCSB-JSA). When I got there, my first question was, "What exactly is the JSA and what does it do?" The liaison officer described it as a "unique" organization composed of both U.S. and Republic of Korea (ROK) soldiers. It is, indeed, unique in many ways.

The UNCSB-JSA is located on Camp Bonifas, not more than a few hundred meters from the Demilitarized Zone (DMZ). (Camp Bonifas is named in honor of Major Arthur G. Bonifas, who was attacked and killed by North Korean troops in the Joint Security Area, along with First Lieutenant Mark T. Barrett, on 18 August 1976.) Every day, soldiers of the United Nations Command are bombarded with communist propaganda, spread in the form of loudspeaker announcements, or large "Hollywood" type signs that litter the North Korean landscape.

Soldiers of the JSA are specially selected and go through a detailed screening before assignment. The battalion is about 60 percent ROK soldiers and 40 percent U.S. soldiers under U.S. command.

Because of its proximity to the DMZ, the UNCSB-JSA maintains a rigid pass and leave policy and offers few of the comforts that soldiers from many other units take for granted. Alerts are called often to test the unit's ability to react to any crisis within the DMZ, and soldiers

are prepared to deploy on a moment's notice.

Missions

The UNCSB-JSA's stated mission is *to provide the Commander in Chief, United Nations Command, a secure environment in which to conduct negotiations with North Korean representatives.* The Joint Security Area (Pan Mun Jom)—an area 800 meters square, composed of buildings, checkpoints, and road networks—is the designated location for all armistice related talks. The Military Demarcation Line cuts through the middle of Pan Mun Jom.

Life on Camp Bonifas focuses on five very different mission cycles that are rotated among the UNCSB-JSA platoons. This rotation gives platoons a change of mission every five days, which helps eliminate boredom and complacency. Thus, the cycle repeats itself every 25 days. The following are the five missions the battalion performs every day:

Conduct security operations within the JSA. Of all the activities that take place inside the JSA, security operations receive the most attention from the UNCSB-JSA staff. The battalion staff anticipates any and all contingencies, usually in the worst-case scenarios. Leaders and soldiers alike learn a complex array of actions that demand swift and effective responses. All the soldiers of the UNCSB-JSA platoons and squads train daily on these drills. They rehearse contingencies constantly, and if adverse actions do arise in the area, soldiers are well trained to handle and eliminate a wide range of threats.

Secure and conduct civil affairs in the village of Tae Song Dong. After the armistice was signed in 1953 and all other villages within the DMZ were removed or destroyed, each side was able to maintain one village. The South chose Tae Song Dong (also known as "Freedom Village"), and the North chose Ki Jong Dong (better known as "Propaganda Village"). These towns stand less than two kilometers from each other, each represented by two large flagpoles.

The Tae Song Dong platoon has the daily mission of providing security for the farmers of the community, which includes escort to and from high-risk farming areas near the Demarcation Line and keeping an accurate record of civilian personnel who are inside the DMZ.

Provide security and logistical support to the Neutral Nations Supervisory Commission (NNSC). When the NNSC was formed at the signing of the armistice in 1953, its original purpose was to monitor troop concentrations and movements inside the Korean peninsula. Czechoslovakia and Poland were designated to monitor forces in North Korea; Switzerland and Sweden were assigned to monitor those in South Korea.

All countries of the NNSC were neutral during the Korean War and had free access throughout the peninsula to help enforce the armistice agreement. In the early 1990s, however, the North Koreans, who were starting to get tired of the "outdated" agreement, began putting pressure on the NNSC in the North. Soon afterward, the Czechoslovakian

delegation disbanded, leaving only the Polish commission. Finally, in 1993, the Polish commission withdrew its personnel, but Poland is still an NNSC member.

Today, the NNSC continues to show support for the armistice agreement by the neutral nations' presence in Pan Mun Jom, but their mission has changed. The Swiss and the Swedish have no counterparts in the North, and they do not have free authority to cross the Demarcation Line as they did in the early 1990s.

Conduct a DMZ orientation program. The DMZ Orientation Program (also known as the "Tour Program") is the mission for which the JSA is best known. The focus of this program is to provide a historical perspective on the Korean armistice, show visitors that the U.S. still has soldiers deployed to Korea, and give tourists an opportunity to see outstanding U.S. and Korean soldiers.

Secure and operate Camp Bonifas. More than 150,000 tourists visit the DMZ every year. Everyone from the President of the United States to a South Korean elementary student has at one time or another ridden a bus through the DMZ. Every week, the Battalion S-1 can expect at least one or two distinguished visitors to enter through the Camp Bonifas gate. Tours are conducted in English, Korean, and Japanese.

In addition to these five missions, the JSA is assigned the "be prepared" missions of conducting Noncombatant Evacuation Operations (NEOs) and retrograde operations.

Because of the battalion's proximity to the DMZ, the battalion considers NEO missions among its highest priorities. The UNCSB-JSA can expect to evacuate more than 600 noncombatants at one time. These noncombatants include Tae Song Dong residents, Korean civilian employees, daily tourists, and NNSC delegates. To be prepared for these missions, the battalion conducts NEO exercises often, and many of the civilians take part in the training.

The UNCSB-JSA is commanded by an American lieutenant colonel—usually one who has previously served in



Curious North Korean guards observe from the other side of the DMZ.

Korea. The deputy commander is a ROK major, who works closely with the battalion commander on all matters. The battalion has an American executive officer (XO) who heads the staff in much the same way as other U.S. battalions. Two sergeants major, one U.S. and one ROK, advise the commander on issues pertaining to the soldiers of either army. Even though there are leaders from two different armies, the UNCSB-JSA command group operates under a single command structure.

The UNCSB-JSA has a very different task organization from that of other U.S. light infantry battalions. The battalion has two organic companies—a Headquarters and Headquarters Company (HHC) and a Joint Security Force (JSF) Company.

The HHC has the standard sections and platoons that support all battalions in the U.S. Army, but with a few additions. First, it has a civil affairs platoon, which is responsible for the daily civil operations in Tae Song Dong. This platoon is kept busy providing security for the villagers and tracking daily farming activities within the DMZ. The HHC also has a Military Police platoon, whose responsibilities range from the security of Camp Bonifas to support for the NNSC.

The JSF Company is made up of four light infantry platoons and a headquarters section. The soldiers and officers in this company are all ROK personnel, except for a few American support personnel in the headquarters section. The headquarters section consists of an

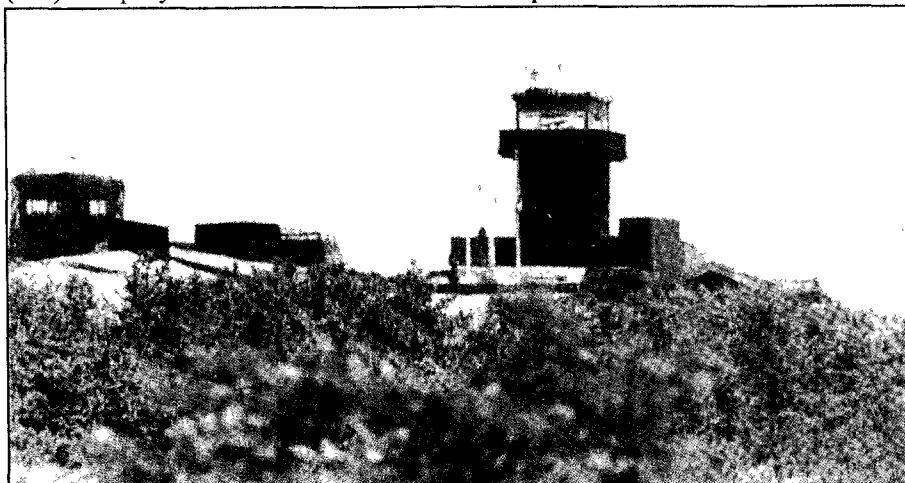

Observation Post Ouellette, the only U.S. guard post in the DMZ.

American XO and a small handful of U.S. supply personnel. The XO holds an important position in the company because he is the link between the ROK company commander (his boss) and the American supply system.

Aside from the battalion's two organic companies, other forces help the UNCSB-JSA accomplish its missions. The battalion has a strong relationship with its close neighbor on the DMZ, the famous 1st ROK Division. This division has a long history throughout the Korean War, and its pride and reputation are still strong today. The JSA and 1st ROK units work closely together and are vital in the mutual support of missions. Forces from the 2d U.S. Infantry Division also support the UNCSB-JSA.

The JSA's main challenges are the language barrier and cultural differences. Because of the ratio of U.S. and

ROK soldiers, communication is an everyday problem. Daily battalion operations are conducted in English, and all ROK soldiers have at least a basic understanding of the English language. Still, so much is lost in translation, especially when military terms, symbols, and jargon are used. (Most U.S. soldiers have little or no knowledge of Korean.)

In addition, the two cultures are diverse, and it is sometimes hard to keep this in mind when working in a battalion consisting of soldiers of both armies. The two armies have different military protocols and procedures. Even an everyday action in one army may be totally unfamiliar to the other. For example, a ROK company commander asked me why U.S. enlisted soldiers did not render salutes to senior enlisted soldiers, which is common military custom in the ROK army.

In summary, the UNCSB-JSA offers the most demanding and diverse range of missions on the Korean peninsula, if not in the entire U.S. Army. Soldiers who serve in this unit will leave with a greater respect for both the ROK and U.S. governments. They will also realize that tactical decisions made inside the Joint Security Area can have strategic level results because of the high visibility of U.S. forces serving within the Security Area.

Captain Keith A. McKinley served as the assistant operations officer for the UNCSB-JSA. He previously served as a rifle platoon leader, support platoon leader, and antiarmor executive officer in 3d Battalion, 327th Infantry, 101st Airborne Division (Air Assault), and now commands Company C, 1st Battalion, 9th Infantry. He was commissioned through the ROTC program at Chicago State University and also holds a degree from Indiana University Northwest.

Ground LOGPACs for Light Infantry

Lessons Learned at the JRTC

CAPTAIN BRIAN TRAYNOR

Aerial resupply, primarily by helicopter, is always the preferred method for light infantry operations. But there are times when an infantry battalion or brigade is forced to use ground resupply techniques, for various reasons—poor weather, a superior enemy air defense effort, the maintenance of helicopters, crew rest, or the inability of the chain of command to task organize air frames for resupply operations because of other mission requirements. It is therefore important for infantry leaders to understand and drill ground logistical operations.

A decision to conduct any resupply operation by ground requires the synchronization of the following battlefield operating systems (BOSs):

- Air defense (Stinger teams or Avenger vehicles).
- Fire support (field artillery).
- Maneuver (infantry squads and armed or hardened fighting vehicles).
- Engineer (breach elements).
- Air support (OH 58s or any aerial weapons platform on call).
- Casualty evacuation (standard and non-standard rotary wing and ground ambulance).
- Communications.
- Intelligence.

The commander of the forward support battalion (FSB) is normally responsible for the overall coordination of convoys leaving the brigade support area (BSA). He and his staff should control the frequency, composition,

combat power, release, tracking, briefing, and debriefing of all convoys leaving and entering the BSA. If these convoys are properly equipped, well coordinated, and well-organized, they stand a much better chance of accomplishing the mission. They can also serve as a valuable source of recent intelligence for activities along the main supply route. The debriefing conducted in the BSA after the mission has been accomplished can then be used to modify the briefing issued by each of the BOS representatives.

The Briefing

Before the unit quartering parties leave, they should be required to attend a briefing in which each of the BOS

representatives within the BSA TOC can update convoy personnel. The convoy commander and subordinate leaders or unit representatives moving with the convoy should receive a one-page document or overlay that contains the following:

- Targets and target numbers.
- Known or suspected enemy locations (snipers, ambush locations).
- Natural and manmade obstacles (minefields, streams, channeling terrain).
- Casualty evacuation (CASEVAC) locations (casualty collection points, ambulance exchange points).
- Frequencies (convoy, medical evacuation, mortar net, or fire support).
- A hasty schematic of the route and destinations—logistics release points (LRPs).
- A contingency plan for disabled vehicles.
- Rally points along the route.

The following BOS representatives need to give five-minute updates to the convoy leaders in the TOC before the convoy leaves. The battle captain on shift can give a quick situational overview for the immediate operational area. The intelligence officer can give a quick update of the enemy situation. The FSO can brief planned targets along the convoy route and inform the firing batteries when the convoys are about to depart and alert them to be prepared to receive fire missions along the route. Medical personnel can talk about the current medevac plan and the locations of CCPs. Finally, the signal NCO or officer on duty can brief frequencies and call signs. Ensuring that the compromise of friendly priority intelligence requirements (PIRs) is kept to a minimum, the one-page overlay will show NCOs and officers within the convoy the support that is available to them.

Because the FSB combat power allocated for convoys depends upon the task force's needs, the force package the task force commander allocates to the BSA will change from one operation to another. The FSB S-3 should consider this and develop battle drills, using the habitual convoy combat power they plan to send with each convoy. These

drills can be incorporated into an easy-to-read battle book that senior representatives from convoy elements can read and disseminate to their subordinates. The following is an example:

STANDARD BATTLE DRILL FOR 10TH FSB LOGPAC (REACTION TO CONTACT):

The convoy/LOGPAC combat power is as follows:

- M55A1 Sheridan (2)
- M1025 HMMWV w/Mk 19 (2)
- Battalion support platoon M998 HMMWV (4)
- Battalion support platoon M923 5-ton (4)
- FSB M923 5-ton w/infantry squad + engineer (2)
- FLA (front line ambulance) M997 (1)
- M998 HMMWV C&C FSB vehicle (1)

The battle book should also address contingencies such as reactions of all elements upon receiving fire.

Easy-to-follow instructions and a sketch for each battle drill should be available. Unit representatives within the convoy must ensure that the drivers and track commanders see the drills and understand them. If infantry support is provided, these soldiers must rehearse the standing operating procedures (SOPs) that they will execute under varying conditions, as they are the convoy's most flexible and lethal asset. Additionally, the commander's intent for mission success for each convoy must be clear. It is not unheard of for a task force commander to want to target any and all enemy personnel during the low-intensity phase at the JRTC. His guidance may go as far as allocating a heliborne quick reaction force that will employ, search, and attack all sightings by the convoy. Therefore, it is important that the mission and intent for the convoy be identified before its potential as a targeting/intelligence collection asset overshadows its primary role as a support asset. LOGPACs and convoys need to target and report enemy personnel and obstacles to support their mission.

LOGPAC Planning

Logistic resupply packages are most

effective when they are well coordinated, standardized operations. To facilitate this coordination, the task force S-4 needs to include an annex for LOGPAC operations in the operations order. If all the battalions roll ground resupply convoys and quartering parties together, the following benefits will result:

- Habitual working relationships between units in the convoy will enable them to react to situations more effectively.
- Routine requesting of fires and aviation support (helicopter gunships and scout overflights) will become easier to execute.
- With the LOGPAC an SOP, move-out times can be more flexible to adjust to METT-T (mission, enemy, terrain, troops, and time).
- With all battalions or companies rolling out together, there is less strain on the limited security assets that have to roll with every convoy.
- The LOGPAC will become a standardized method for moving all types of items, including ammunition, water, personnel replacements, dunnage, trash, mermite, and hard copies of reports, if necessary. As units identify assets that need to be moved, they can default to the LOGPAC as a habitual method of delivering items. This will reduce the number of "emergency resupply" missions that need to be executed due to poor planning every day.
- This will reduce stress on the combat BOSs providing support to resupply missions, allowing them to spend more time supporting standard combat operations.
- The time for the unit representatives to receive their convoy briefing and move out should be disseminated 36 hours before the time of execution, but the convoy time should vary to keep from establishing a traffic pattern for enemy observers.

The Logistics Release Point

The purpose of the logistics release point (LRP) is to provide a geographic location where units can separate from the convoy/LOGPAC they are accompanying and meet their own subordinate elements to distribute classes of supply,

personnel, etc. In a battalion-sponsored LOGPAC, the LRP would be the linkup point for company supply representatives and the convoy coming from the BSA field trains to receive supplies before driving to their company area.

There are many techniques for conducting actions at the LRP. The method described here is a compilation of lessons learned and proven SOPs from the training centers. (The following information discusses techniques, not doctrine.)

The subordinate units receiving supplies from the LOGPAC should always arrive at the LRP before the supporting convoy so that they can perform the following tasks:

- Provide local security for themselves and the arriving LOGPAC.
- Provide LRP control, assume guidance of inbound vehicles, and provide a far-side recognition signal.
- Prepare mermite dunnage, empty fuel cans, trash, and waste products from the previous LOGPAC so they can be easily picked up for return.
- Have assets on hand to receive and transport inbound supplies and personnel from LOGPAC to unit areas.
- If possible, have the same person-

nel from the subordinate units always receive their breakout of supplies from the LOGPAC.

When the units arrive at the LOGPAC and divide the supplies, they must adhere to a definite schedule and have a detailed contingency plan if they are to return items and information to the LOGPAC in time for its return trip. A good planning time is three hours from the time units link up at the LRP. This gives unit supply sergeants an hour to travel to their companies, an hour to feed personnel and drop off supplies, and an hour to get back to the LRP to meet the convoy/LOGPAC before it goes back to the BSA. This planning time depends, of course, upon the mission and other factors of METT-T.

The following are examples of items that units normally send back to the BSA:

- Weapon systems and equipment to be evacuated for repair.
- Personnel in need of transportation to be processed through the BSA (emergency leave, prisoners).
- Logistics reports or other hard-copy information.
- Gasoline and water cans that need to be filled.

- Air items that need to be returned to the BSA or unit field trains.

- Non-mission essential equipment to support future operations.

- Trash, dunnage, and waste products.

Security assets and combat power escorting the LOGPAC remain in place at the LRP until the convoy is ready to return to the BSA.

While ground convoys may be more vulnerable to enemy contact and obstacles than air delivered assets, they often become a reality during the course of combat operations. By planning and rehearsing the actions necessary for the successful completion of ground convoys, units will be more prepared to execute these missions when they need to be carried out. In ground LOGPAC operations, planning, coordination, and rehearsal are vital to success, just as they are in any other combat operation.

Captain Brian Traynor served as a rifle platoon leader, antitank platoon leader, and headquarters executive officer in the 6th Infantry Division, and as brigade assistant S-4, brigade S-3 Air, and Assistant G-5 in the 10th Mountain Division. He is a 1992 ROTC graduate of North Georgia College.

Fighting in a Fortified Village

In the Second Chechen War

ADAM GEIBEL

Military operations on urban terrain (MOUT) is currently a hot topic in the U.S. Army, with computer simulations and field training exercises focused on how to survive a battle in a metropolis. Most of the world's people, however, still live in small villages more like those of the people of the 18th or 19th centuries. In the rugged mountains of the Caucasus, the Russians have re-

learned just how hard it is to take a fortified village garrisoned by well prepared and determined defenders.

With the capital city of Grozny abandoned by the Chechens in early February 2000, the next stage of the Second Chechen War moved south—into the mountains, where the Russian command believed that up to 8,000 armed Chechens awaited them. The Argun

and Vedeno Gorges cut deep into these mountains and served as major supply and movement corridors for the Chechen fighters.

The Argun Gorge had been heavily contested in the First Chechen War (1994-96) and was still reportedly littered with burned-out armored fighting vehicles (AFVs) from that conflict. Federal units had been fighting the

Chechens at the entrance to the gorge for weeks, even before the capital fell.

On 21 February, Federal troops moved on Shatoi (25 miles south of Grozny), seized heights near the villages of Makhety and Selmentazhen (east of the gorge). By this time, the Russians estimated that the Chechens had 4,500 men under arms in the Argun Gorge.

Since the war had moved into a phase where tactics similar to those of the Mujahideen favored the defense, securing the mouth of the gorge meant sweeping any Chechen units from the hillside villages. Small units could easily hit Russian logistical convoys and return unhindered to their village bases.

One such small village was Komsomolskoye, in the Urus-Martan district very close to the mountains. (It is four kilometers west of the mouth of the gorge, seven kilometers from the district center of Urus-Martan, and 25 kilometers south of Grozny.) As the spring thaw approached, the town was described by Russian sources as the last major pocket of "rebel" resistance in southern Chechnya.

Opening Shots

Fierce fighting was reported around the villages of Komsomolskoye and Roshni-Chu on 3 March 2000. The next day, the Russians would claim that Yaroslavskaya Oblast (Special Unit Militia Detachment) UVD (Internal Affairs Administration) destroyed a 100-man Chechen unit near Komsomolskoye.

On 5 March a Chechen Mujahideen unit "slipped in and took control" of the small town. The Russians estimated that this garrison initially contained 500 Mujahideen—Chechens, Arabs, Ukrainians, and Chinese, and even some Russians led by field commander Ruslan Gelayev.

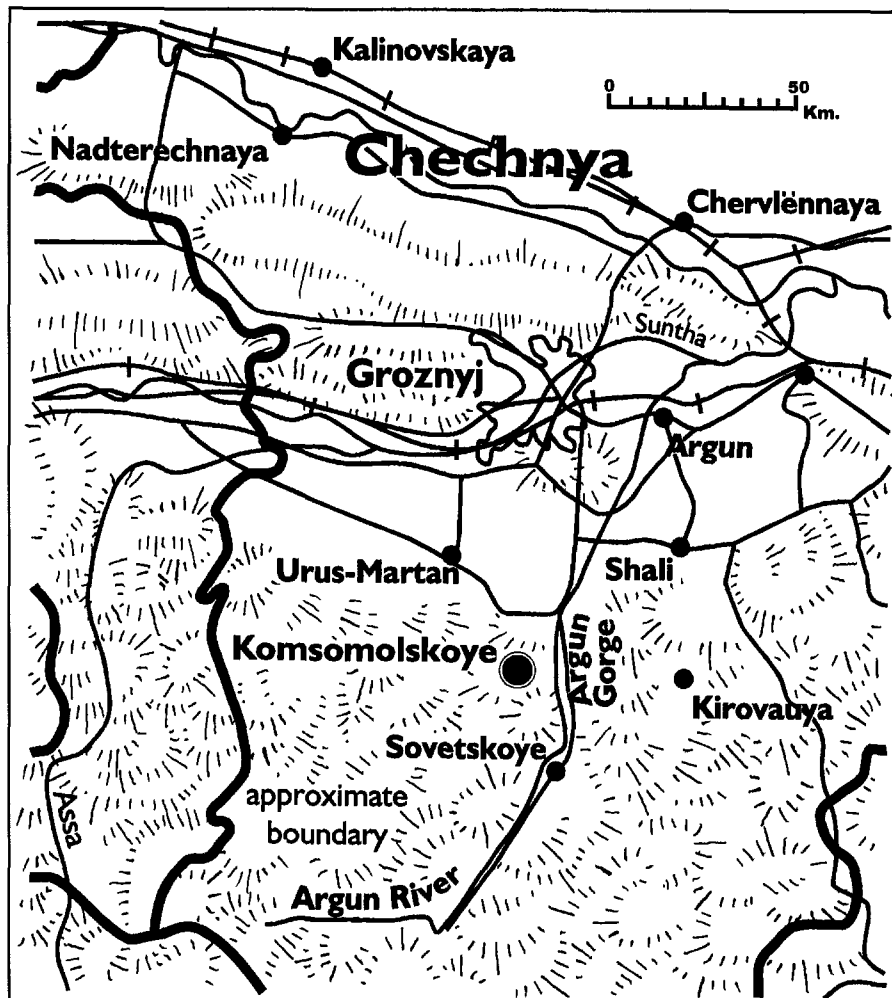

The Chechens must have prepared the town well in advance, however, since Russian servicemen later described every house as a pillbox. Beneath almost every building, there was a two-level cellar with strong ceilings. These strongpoints were linked by underground communications trenches (or tunnels), with covered earth and timber firing points in the back yards and at select crossroads.

Most of the pillbox homes had to be stormed with airpower and artillery. Russian artillery targeted the town on the 6th in an effort to oust the fighters. By midday, almost all the buildings on the southern edge of the town had been

destroyed. One unnamed Russian officer manning a checkpoint near the town claimed that up to 50 Russian troops had been killed in action and many others wounded since the 4th.

The next day the Russians claimed to have had 700 to 1,000 Chechens bottled up in Komsomolskoye. They realized that this was equivalent to a regiment and that odds of three-to-one would be necessary to clear the village. In the first week of the siege, Interior Ministry troops—including SOBR (special rapid reaction detachments), OMON (special-purpose militia detachments), and special troops of the Justice Ministry's main penal department—managed to clear only the center and northern outskirts of the village. (On 17 March the Human Rights Watch group told a news reporter in Nazran, Ingushetia, that some 2,000 civilians were trapped in Komsomolskoye for several days under fierce bombardment before Russian forces finally let women and children out.)

AUTHOR'S NOTE: The Second Chechen War was still being fought as this article was written. The following was assembled from media sources—Russian, Western, and Chechen. Since there is little chance that either side will ever issue an official history, my efforts here are an attempt to reconstruct the events surrounding the siege of the village of Komsomolskoye. (Corrections, additions, and photographs would be welcome, care of the editor of INFANTRY.)

A note on spelling: The town name was also spelled "Komsomolskaya" in some Russian reports and called "Saddi-Yurt" by the Chechens, with the alternate spelling of "Saadi-Khutor." For simplicity, I have kept the spelling used in most western reports.

The initial absence of motorized, naval, or airborne infantry conformed with Russian strategy during the Second Chechen War, in which Interior Ministry units (whose personnel are as much policemen as they are soldiers) were charged with "mopping-up" operations.

On the 7th the Russians estimated that the Chechen force had grown to 700 but that Gelayev's deputy commander, Khamzat Idigov, had been killed. The Russians admitted that it was difficult to locate Chechen communication points, since they didn't use radios or satellite communication systems. Russian artillery targeted positions within the town with round-the-clock strikes, while fighter-bombers made low-altitude passes every five to 10 minutes, dropping bombs and firing rockets.

Some Komsomolskoye residents fled the bombing, spending the night in a nearby field. They said the Russians were preventing civilians of surrounding hamlets from bringing food or water in to them, and that the fighters had taken up positions in the village mosque. Russian Defense Minister Igor Sergeyev told the press that up to 1,000 fighters were believed to be in or around Komsomolskoye.

Toward sunset on 8 March, Federal forces were "mopping up," the village occupied only by small groups of fighters offering stubborn resistance while trying to break out of the encirclement.

The Chechens said that the fighting had expanded, during 7-9 March, to the villages of Goyskoye, Alkhazurovo, and Rozhni-Chu. They claimed that about 70 Russians were killed, four taken prisoner, and three AFVs knocked out near Saadi-Khutor and Goyskoye.

Russian tanks and howitzers in direct-fire mode, supported by pairs of fighter-bombers, pounded the village on the 10th. The commander of one Russian motorized rifle regiment would later admit to losing 32 of his men during the siege. A tank battalion commander known only as "Sanya" said, "We stood up above, in the foothills, and attempted to not let the guerrilla reinforcements into the village. At first, I sent one [tank] crew to assist, they set it on fire, the second went in, and it also

caught fire—just like a candle. The lads called fire in on themselves. And that's all.... They were less malicious in the last war, but right now they have come in waves, they moved like they were in a psychic attack! We were trashing them using direct laying and they kept coming and coming....When we beat them back with difficulty, we found 150 of their corpses."

Speaking unofficially, Russian troops told the press that they had lost 11 KIA since the fighting started on the 5th. The Chechens counterattacked and forced a Russian unit back to the edge of the village, claiming 100 Russians KIA in the fight. The Mujahideen occupied positions beyond the village, controlling the road to Surat and two nearby tactical heights.

That same day, General Gennady Troshev (acting head of Russia's forces in the North Caucasus) said that Gelayev had been seriously wounded in fighting at Komsomolskoye. Colonel-General Valery Manilov (first deputy chief of the general staff) noted that the village was "tightly encircled" and that the Chechen force numbered 300-700.

A two-hour morning firefight followed, after which the Chechens announced the loss of 23 KIA and 30 WIA. They also noted that two Russian attempts to entrench within the settlement, as well as an assault on Chechen positions later that day, had failed. According to the Chechens, 75 Russians were KIA and two personnel carriers were knocked out when mobile Mujahideen units ventured out several times and attacked Russian units north of the town. During one of these firefights, the 22-man Irkutsk SOBR lost Lieutenant Vladimir Idashin and Private Salim Konchir-oola to a Chechen sniper.

The Chechens said that they handed over the bodies of 26 Russian Spetsnaz (special forces) soldiers and evacuated 37 of their own wounded, during a mutual cease-fire negotiated with the Russian command on the 14th. They added that 60 Russians had been killed for the loss of nine Mujahideen, but a Russian spokesman named Baranov admitted to only five army servicemen KIA and ten WIA on that day. Other Russians said that Gelayev had slipped out of Kom-

somolskoye. Defense Minister Sergeyev claimed that Federal troops foiled an attempted breakout by 120 fighters, at least 20 of whom had been killed.

When the cease-fire ended several hours later, combat resumed with a vengeance; Russian artillery and multiple rocket launchers pounded the town.

Around 1200 Moscow time on 15 March, Colonel Mikhail Revenko (deputy commander of the western federal group in charge of equipment and armament) was killed while suppressing a pocket of Chechen resistance in the west of the village. He had positioned his tank to fire at them point-blank and came under Chechen grenade fire as he left the vehicle.

After ten days of fighting, the Russians announced that they had taken the village on the 15th. Soldiers in mopping-up operations had to exercise extreme caution in the village, since the cellars and ruined homes still held fighters, booby-traps, and mines. Sniper fire kept Russian forces from advancing; two interior ministry generals came under fire near the settlement but escaped injury.

The Mujahideen claimed to have beaten back five separate Russian assaults on the village before retiring into the mountains.

On the 16th, "Alpha" and OMON units were working under thick plumes of smoke to clear out Chechens still holed up in the village. The Kremlin said that about 300 bodies and 90 fresh graves had been discovered in the village that day, a report that was impossible to verify. One Russian officer (going by the name of "Oleg") admitted that they suffered an unspecified number of casualties to several dozen Chechen fighters who had stayed behind and attacked Russian positions during the night.

Russian losses continued to mount, particularly on the 17th in one tragic incident from a case of fratricide. The Irkutsk SOBR had just taken a small hill after a difficult fight when they came under fire from a lone Russian tank. The Irkutsk unit had radioed that the Chechens had fallen back and were shocked when the tank fired up the very hill they had just taken. Newly pro-

moted Majors Aleksey Rybak and Andrey Fedotov, along with trooper Aleksey Koshkin, were killed and five others wounded. (The units' 12 survivors were sent home on the 20th, presumably because the SOBR men wanted to start a fratricide investigation).

The Chechens claimed that the total Russian casualty count for the Komsomolskoye battle to that point was 400 killed and 37 AFVs knocked out, for 30 Mujahideen killed and 37 wounded. Only Chechen mobile "covering" and "special" units remained in the area around the village.

But Russian television showed footage of the streets, strewn with bodies of Chechen fighters and dead farm animals. Leaving several dozen fighters behind to play a cat-and-mouse rear-guard action, the majority of Chechen defenders broke into teams of three to ten men each and slipped away into the forests or to Alkhazurovo (just east of Komsomolskoye), which sent that town's citizens fleeing as well. Russian intelligence claimed that other Chechen sub-units were regrouping in the Veden, Kurchaloi, and Nozhai-Yurt districts, intending to break through to Dagestan.

Two Chechen fighters (17-year-old "Adam" and his friend "Mansur") would later tell AFP how they exfiltrated. Mansur noted that the Russians were "frightened of us." He went on to say, "In the mountains there are no clashes, just bombardments. When we left Komsomolskoye they were 50 metres (150 feet) from us. A soldier saw us go past, he told his neighbor who warned a third and then nothing happened. They fired on us when the column of 150 fighters was already a kilometre away."

Shifting their defense to a new town would force the Russians to divert units to block the Chechens, or face leaving their rear service elements open to night attacks by small bands of Mujahideen.

Knowing this, Russian units withdrew from Komsomolskoye to a safe zone about a mile away, set up artillery, and prepared to renew their offensive against Komsomolskoye on the 19th, since a band of about 400 Chechens were still holding out in the southern

SHARO-ARGUN

Colonel General Georgy Shpak, commander of the Russian airborne troops, told the Russian press: "The rebels are constantly on the move, appearing in one village of the republic or another. Groups of 15 to 20 rebels infiltrate villages in the plains from Chechnya's mountainous areas.... They easily blend in with the peaceful residents, making it difficult to identify them. They are civilians by day, and armed bandits by night."

The Russian command had stumbled onto what was originally reported as a "well-fortified Chechen base deep in the mountains" on 16 March, in a settlement called Sharo-Argun (about 15 miles southeast of Urus-Martan). The Russians initially estimated that the Jordanian field commander, Khattab, and 500 fighters were

based in a stronghold that included a field hospital and a munitions dump and fortified with dug-in tanks.

Sergei Yastrzhembsky announced that a mopping-up operation was to begin that day and the Russians dumped as much ordnance on the fort as they could bring to bear, and the Chechen units displaced on the 17th.

This easy victory could be explained by AVN, in that Sharo-Argun was actually only a temporary base on the infiltration route into the Botlikh and Tsumadinsk districts of Russia's Dagestan republic. Mopping-up operations were still going on by the 21st, however, against what the Russians described as "kamikaze snipers who are mostly foreign mercenaries or irreconcilable Wahhabis."

part of the village. (This prudent move still did not deter a Mujahideen daylight attack on a multiple-launch rocket system (MLRS) battery near Martan-Chu, which resulted in three Russian wounded on the 20th.)

Gennady Troshchev claimed that his troops had killed 42 Mujahideen and, under occasional sniping, were combing the village's ruins in search of surviving fighters who may have been hiding in cellars.

The Russians also theorized that Gelayev, whose radio call sign was "angel," had been killed on the 19th, since no one had heard from him for days afterwards. (These claims later turned out to be false.) Troshchev added, "Five guerrillas we took captive say the rebels' leader, Ruslan Gelayev, is hiding with his two sisters in one of the cellars. Most of the surviving bandits have understood the hopelessness of their predicament and have fled in different directions."

However, Defense Minister Sergeyev said that Russian forces killed 45 Chechen fighters at Komsomolskoye in a 24-hour period on 19-20 March. The resistance—mostly sniping—was kept up by an estimated 50 Chechens.

A tank company fired point-blank at the Mujahideen-held houses for 60 minutes. At around 1500 Moscow time,

the Mujahideen offered a truce to Federal troops, but the offer was rejected and, an hour later, the Chechens started surrendering (this time was also reported as 1400). Up to 76 fighters (including two women) supposedly surrendered before a Russian flag was hoisted over the village that evening.

Komsomolskoye had been flattened, and the Russians claimed that up to 700 fighters had been killed. However, Russian military sources told the Russian Military News Agency (AVN) that Federal forces had lost more than 50 KIA and 300 WIA in the siege and storming of Komsomolskoye.

The Russians caught one unit trying to break through the cordon to nearby Urus-Martan in a hollow south of Komsomolskoye. They claimed to have killed 30 Mujahideen and captured 40 in a three-hour battle on the night of 20-21 March.

Sergey Yastrzhembsky was telling the press that the battle was over (with 600 Mujahideen KIA and 88 prisoners taken) on the 21st, one of the Chechen leaders radioed the federal command and claimed that 150 fighters were ready to surrender. This turned out to be a ruse, and tank units had to eliminate separatists at several strong points. In the section of town that the Russians did control, they found 53 dugouts and

eight "long-term firing points," as well as a huge amount of munitions.

The last Chechen snipers were supposedly cornered in a basement on the 22nd and, after refusing a surrender offer, were blasted into silence by Russian tanks.

Army sappers started clearing the town of mines and other ordnance on the 23rd. Other Chechen units exfiltrated and tried to slip into the surrounding Sharoi, Vedenov, and Nozhai-Yurt districts. Federal intelligence said that the Chechens planned to take the villages of Shali, Dargo, and Urus-Martan on 25-26 March.

Aftermath

A month after the battle began, rotting corpses were still in the streets. Wrecked T-80 main battle tanks and APCs still sat in the streets. (*Since Russian journalists are not specialists in armor recognition, the tanks may have been T-72s.*) The village, quiet save for occasional sniper shots and the sound of helicopters, was described as "looking like a pile of shattered matchsticks—not a single building was left intact."

The Ministry for Emergency Situations workers, who were tasked with removing civilian corpses and taking them to the nearby village of Goyskoye for identification, said they had recovered 265 corpses over the previous week (including 58 on the 3rd alone). They also collected bodies lying by the river, some of which had ears, noses, or fingers sliced off. It was not known who had mutilated the bodies, or why.

More than 60 bodies from Komsomolskoye were delivered to Goyskoye

(20 kilometers south of Grozny) by Kamaz truck, but only six of them had been identified. Abdula Itskayev, headman of Goyskoye said that there were heavy casualties among the town's civilians and claimed to know whole families that had been killed.

Russian military casualties had been removed by the military before the Emergency Ministry workers arrived. According to Sergeant Andrei Alexeyev, "Our side suffered colossal losses. After bombardment by aviation and heavy artillery they sent 200-300 men in....Of them you'd get groups of two or three crawling back injured."

Serviceman Sergei Koshmarov described the helicopters carrying wounded soldiers leaving Komsomolskoye as being "like buses in a rush hour." One officer saw four helicopters carrying dead bodies leaving Komsomolskoye on one day. No one seemed to have a firm handle on how many servicemen died during the battles for Komsomolskoye. The Defense Ministry admitted to only 22 servicemen KIA and 100 WIA, while the Interior Ministry provided no relevant information.

The next day, doctors and Emergency Ministry experts estimated that 70 percent of Komsomolskoye had been sanitized. Deputy Prime Minister Nikolai Koshmanin in charge of Chechnya affairs reported that 424 Mujahideen had been buried, as well as more than 360 cattle.

Special brigades were still searching for the dead among the rubble and more than 300 rebel bodies remained unburied on the minefields outside of the village. According to Emergency Ministry

spokesmen, federal sappers would start lifting the minefields after Komsomolskoye was completely cleared of explosive devices. The Unified Federal headquarters noted that 519 bodies had been buried, and on the basis of this count, estimated that the number of defenders had been 1,500. As the cleanup continued, a cache of large caliber machinegun ammunition was uncovered near the village on the 6th.

The Russian media announced that 33-year-old Chechen field commander Magomed Khaykharoyev (the younger brother of the "Bamut battalion" commander Ruslan Khaykharoyev) had been detained by federal forces during their sweep of Komsomolskoye. The Russians also reported that Khaykharoyev's relatives had proposed exchanging him for several captives.

By the time the Russians announced that operations ceased on the 10th, 552 Chechen bodies had been buried and 4,622 pieces of explosive ordnance had been cleaned up.

While we know little as to the exact casualty figures, it is most likely—given the experience, motivation, and tenacity of the Chechens, and the comparative inexperience of Russian units employed—that the Russian losses were several times those of the defenders.

Adam Geibel is S-2 of the 5th Battalion, 117th Cavalry, New Jersey Army National Guard. A graduate of the New Jersey Military Academy Officer Course, he has led both tank and scout platoons. He is also a correspondent for the *Journal of Military Ordnance* and a free-lance writer on military subjects and affairs.

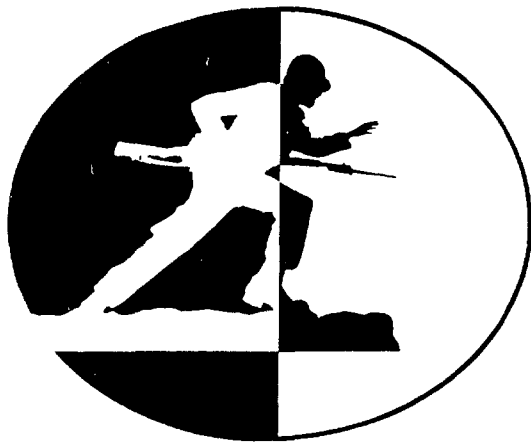

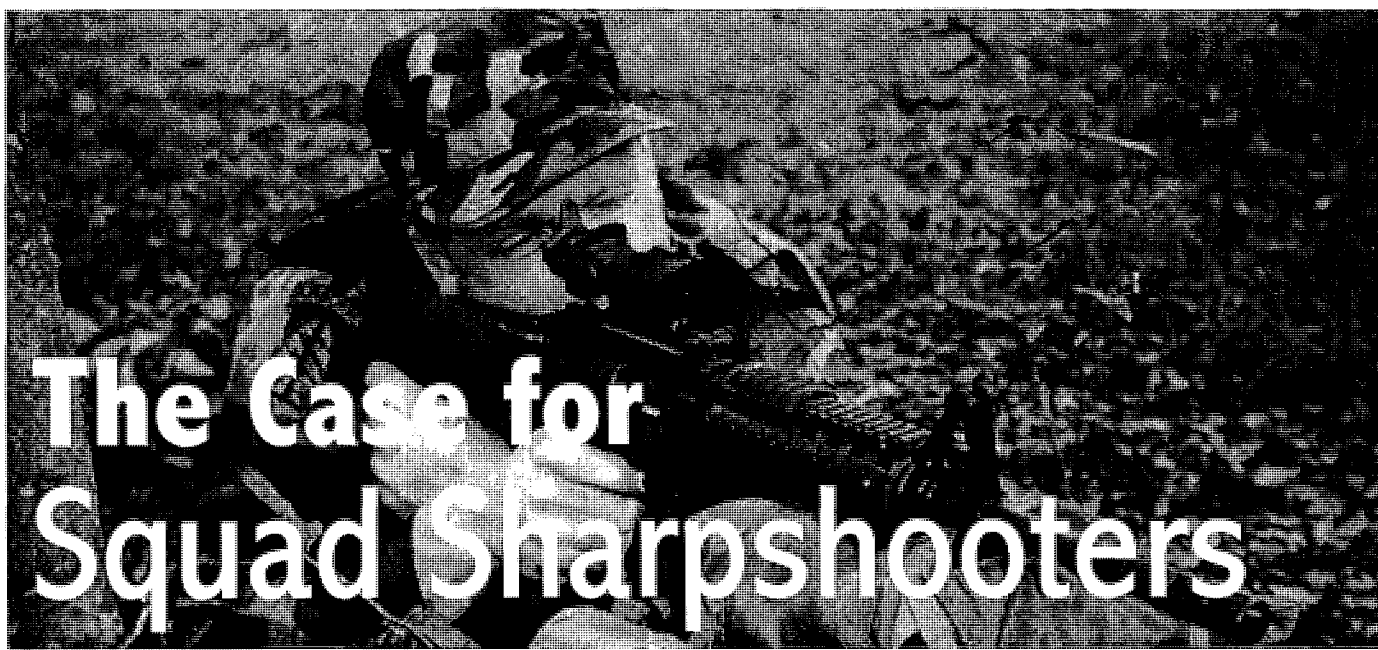

LIEUTENANT COLONEL MICHAEL R. HARRIS, U.S. Army, Retired

In the most basic sense, having a sharpshooter in a squad is a matter of selecting the best shot and giving him a rifle with a telescopic sight. The sharpshooter would employ an optically enhanced M16/M4, standard ammunition, and the training available within the unit's resources to improve the squad's target engagement capabilities at short and medium ranges. In contrast, snipers use specialized rifles and match-grade ammunition, and are specially selected and trained to provide precision fire at medium and long ranges.

The single squad sharpshooter would engage visible point targets, with a priority of engagement to enemy leaders, personnel with radios, machineguns and rocket launcher crews, and sniper teams. This concept could easily be extended to one sharpshooter per fire team. The sharpshooter would retain the standard rifle M16/M4 but with a day optical scope (DOS). The telescopic sight's ability to improve a shooter's ability to acquire targets will increase the number of targets that can be located and engaged. This inherently improves the scope-equipped sharpshooter's situational awareness.

The U.S. Marine Corps Designated Marksman Program is looking at equipping the assistant fire team leaders with scoped M16s. The Rangers have had excellent results providing squad and fire team leaders with the DOS and the rest of the squad with the close combat optics (CCOs). The non-commissioned officers (NCOs), who have had more marksmanship training and experience, can effectively employ this enhanced engagement capability. The enhanced vision sup-

ports their leadership responsibilities by giving them a better look at the enemy and the terrain.

While a rifleman sharpshooter may see targets the leaders cannot, letting the individual soldier make the decision to initiate contact, or *shoot/don't shoot*, may not be appropriate in many situations. DOS-equipped squad and fire team leaders, on the other hand, can make that decision and use tracers to mark precisely where the rest of the element is to concentrate fire. The SEALs, Special Forces, USAF Special Tactics Squadron, Australian SAS, and the Israelis use the DOS as both an enhanced battle rifle and a light sniper rifle, depending on the situation. In some special operations scenarios, every member of the unit is equipped—terrain and enemy permitting—with a day optical scope. One or two DOS-equipped sharpshooters per squad would give the infantry the greatest return on the investment in combat capability.

"We've tried scopes before."

In the past 30 years the infantry has looked at telescopic and reflex sights several times without demonstrating a significant increase in capability. The advanced combat rifle (ACR) program had weapons with optical sights, and after its failure, the idea of equipping the M16 with a telescopic sight was tested. When the optical sight test showed no significant improvement, the Army tested and adopted a reflex collimator sight called the aimpoint close combat optic. A

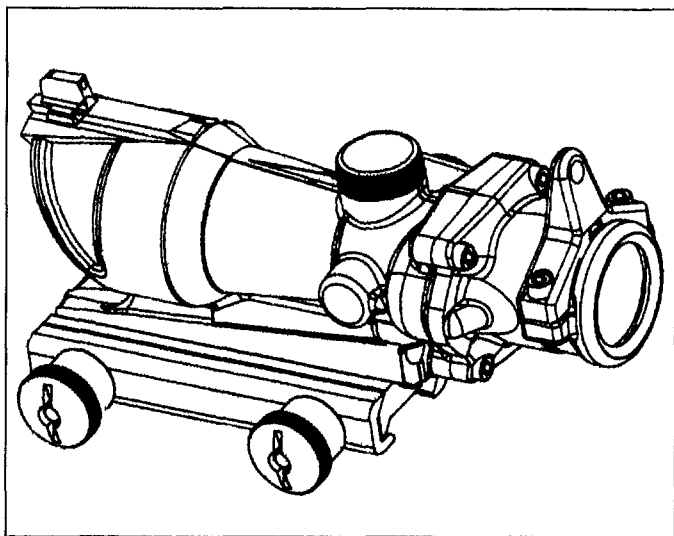

Day Optical Scope (NSN 1240-01-412-6608, Telescope, Model TAO1M4A1)

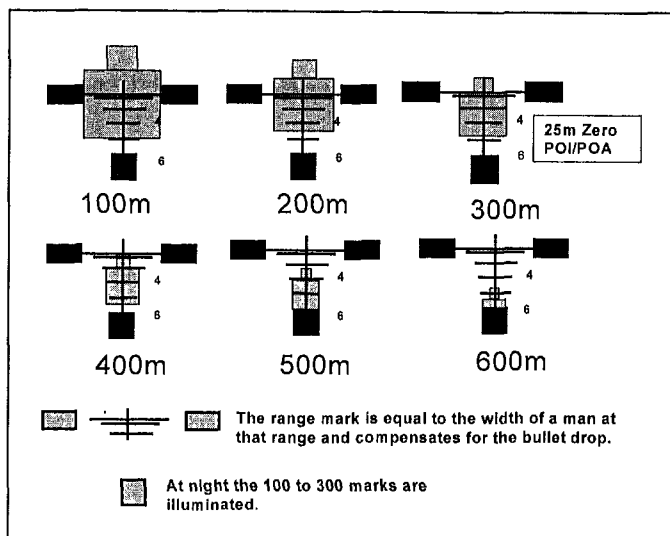

Day Optical Scope ranging and bullet drop compensating reticle

review of these past efforts provides several important insights that relate to the sharpshooter concept.

The SALVO, special purpose individual weapon (SPIW), and advanced combat rifle (ACR) all tried to compensate for individual aiming errors by using a controlled dispersion of multi-projectiles or a burst instead of single well-aimed shots at partially concealed targets. The optical sight test showed no significant increase in hits over iron sights out to 300 meters. The close combat optic showed only a slight increase in average hits, very similar to the reflex sight tests in the 1960s and 1970s.

So why have a sharpshooter with a telescopic sight?

We must remember that these programs were trying to improve the average soldier's marksmanship with an equipment solution (many of the test subjects were not even infantrymen). But there are no gadget solutions to marksmanship training. A marginal shooter with a sniper rifle is still a marginal shooter. If a soldier's position is wobbly and he jerks the trigger, he's lucky if he hits the 50-meter target. In all of these tests, average shooters produced only average scores, while sniper level shooters could hit all the targets with iron sights, and could probably do so even if they were on muskets.

The sharpshooter concept is intended to provide the scoped weapons only to expert marksmen. While the optical sight test showed little improvement out to 300 meters, the data from an early version of the DOS showed significant improvement in hits beyond 300 meters. Once again, the marginal shooters shot poorly, and the excellent shooters hit targets out to 300 meters. Averaging the scores yields average results. For targets beyond 300 meters, and even head shots at 100 meters, the shooter must allow for the bullet's arched trajectory. The DOS has a ballistic compensating reticle that enables the shooter to estimate range and correct for the bullet drop, all in one step. The keys to hitting targets at 300 to 600 meters are a high level of skill in the marksmanship fundamentals and a fast way to compensate for bullet drop. Hits beyond 600 meters require a more accurate rifle, match ammunition, precise range estimation, a highly

developed ability to read and hold off for wind, and precision shooting skills—in other words, a trained sniper.

Both scopes and reflex sights eliminate the errors caused by misaligning the front iron sight in the rear peep. Most shooters who make this error also have problems with steady hold and trigger control. The individual's shooting skill limited these previous tests and masked the system's true potential. The targets in the tests—E-type for the most part—were fully exposed for three to five seconds. The DOS is faster than iron sights in target detection and identification, sight alignment, and range estimation or correction. The tests did not measure any increase in the speed of engagement. A significant tactical advantage can be obtained in combat by forcing an enemy accustomed to making 5-second rushes to make 1.5-second rushes. The close combat optic's major advantage, as shown in testing, was speed in engaging multiple targets (2 to 30) out to about 200 meters. The reflex sights have a major advantage in close quarters battle or in close terrain from 3-50 meters as well as during firing while moving—running, from vehicles or from helicopters—and when engaging moving targets. During the test very few targets were hit at 250 to 300 meters. In all these tests the targets were primarily full E-types, exposed in the open. In combat, the targets would be camouflaged and would often briefly expose only the head and shoulders to fire or crawl forward. The biggest advantage of scopes was not tested or scored: The scope lets you *see* better, not *shoot* better.

The DOS is designed to provide enhanced target identification and hit probability for the M4A1 carbine out to 600 meters. Although it is designed primarily for use during the day, it has a tritium-illuminated reticle for use at night and in low light conditions. The DOS is a lightweight, rugged, fast, and accurate 4-power optical scope. The body is machined from aluminum forgings, and the material and finish are identical to those of the M16/M4. The scope is internally adjustable so that any shock from rough handling can be absorbed by the scope body instead of the adjustment mechanism. For night operations, a night vision adapter can

be added, or the DOS can be removed and a night vision sight attached. Close-range engagement iron sights on top are used for close quarters battle.

Employment of the Squad Sharpshooter

A squad sharpshooter improves a unit's firepower and augments the various ways of harassing and destroying the enemy. The DOS-equipped sharpshooter can support combat operations by overwatching and delivering precise fire on selected targets. This creates casualties among enemy troops, slows enemy movement, frightens enemy soldiers, lowers morale, and adds confusion to their operations. The enhanced vision provided by the 4-power optic helps in locating and identifying targets as well as in collecting and reporting battlefield information.

Even if most of the engagements are expected to be at close range and the squad is primarily equipped with close combat optics, one to three members should be selected as squad sharpshooters and equipped with the DOS. The DOS-equipped soldiers enable a unit to engage point targets at distances beyond the normal effective range (300 meters) of rifles and carbines. Stand-off is always an advantage because it reduces the potential for friendly casualties while inflicting casualties on the enemy and disrupting his movement. Squad sharpshooters can fire in pairs or alternately, or fire and then change positions. They can engage leaders, radio operators, and weapons crews to delay, disrupt, harass, deceive, and confuse the enemy in meeting engagements or suppress threat forces to support maneuver by friendly elements.

The importance of the sharpshooter cannot be measured simply by the number of casualties he inflicts upon the enemy. Realization of his presence instills fear in enemy soldiers and influences their decisions and actions. The role of the squad sharpshooter becomes even more significant when the target is entrenched, positioned among civilians, or part of a civil disturbance. The suppressive firing of weapons in such operations can result in the wounding or killing of non-combatants. During testing and actual combat engagements, DOS-equipped shooters were able to limit fratricide and collateral civilian casualties, and verify targets before firing

under the restrictive rules of engagement.

During urban combat, engagement ranges are often relatively close (50 to 100 meters), but the threat may be well hidden and protected from small arms fire. The DOS-equipped sharpshooter is better able to locate small apertures or loop holes (six to ten inches), acquire the target through the opening, and shoot, or engage small exposed portions of a target. Again the problem is locating the target.

The Tactical Advantage of Range

Historically, most small arms engagements occur at what are considered close to medium ranges. British studies in World War II indicated that 80 percent of *effective* rifle and light machinegun engagements took place at less than 200 yards (183 meters) and 90 percent at less than 300 yards (275 meters). U.S. studies on the M1 Garand in the Korean War showed that 95 percent of all firing was at targets within 300 yards and that troops tended to engage at about 120 yards.

These are relatively close ranges, especially considering that the weapons of World War II and the Korean War fired the much larger and more powerful U.S. .30 caliber 1906, British .303, Russian 7.62X54mmR, Japanese 7.7mm type 92/99, or German 7.9X57mm cartridges. The iron sights on these weapons were graduated up to 2000 meters or more, and the doctrine and training of the period supported long-range rifle fire. The power of the weapon, doctrine, and training does not dictate actual engagement ranges.

A more recent study, the results of which are depicted here, shows the types of engagements and ranges expected in open desert terrain. The key is to understand that both sides in these historical engagements used the unaided eye and iron sights to acquire and hit targets. An understanding of the factors that limit effective engagement ranges helps the infantry equip, plan, and train to maximize battlefield capabilities.

The factors that have always limited engagement ranges in combat have been the limitations of the human eye, the use of iron sights, and the level of training the soldiers have received. The unaided eye can locate and identify exposed human targets out to about 300 meters. Human targets wearing camouflage, maintaining a low profile, and using cover and concealment are difficult to detect even at close range. Light conditions and the problems associated with focusing through iron sights may not allow a soldier to see the target and aim at it simultaneously. The small long-range iron sight aperture decreases the light that reaches the shooter's eye; a target barely visible to the naked eye fades away when he tries to aim at it. Concerns about fratricide may prevent the soldier from engaging targets that he cannot clearly identify. The coatings on the lenses of reflex sights and close combat optics also decrease the light to the eye. The DOS is a 4X32mm optical sight. The 4X means that objects appear four times closer or larger, which means a soldier can see four times as much detail. Dividing the size of the objective



Sharpshooters provide a trained base to draw on for sniper training.

lens (32mm) by the magnification 4X gives an exit pupil diameter of 8. Exit pupil diameters of 5 or more gather light and aid in low-light vision, which is why binoculars come in 7X35mm, 8X40mm, and 10X50mm. Soldiers equipped with the DOS can see four times better than soldiers equipped with iron sights or reflex sights. They are significantly better able to locate and identify targets.

The trajectory of modern small arms ammunition requires very little correction when using a battle sight zero of 250-300 meters. Qualification records show that most soldiers hit very few of the 300-meter targets, either missing them or failing to engage them at all. (A shooter who fails to engage is usually allowed to alibi, and then fires any leftover ammunition at the 50 targets.) Changing the full E-type silhouettes used on qualification to the prone F-type would provide a more realistic course of fire and illustrate that the effective range, for most shooters with iron sights, is about 200 meters, as concluded by the combat studies. Human eyesight, iron sights, bullet trajectory, and the existing level of training are factors that make 200 to 300 meters the maximum practical range for most small arms engagements. However, an M16A2 or M4 zeroed for 300 meters is shooting 6 to 8 inches high at mid ranges (100 to 200 meters). Aiming at the center of an exposed head or firing port at 100 meters will produce a miss. The iron sights have a mechanically set bullet drop for ranges beyond 300 meters, but this does not improve a soldier's ability to estimate range before cranking in the adjustment.

In earlier history, soldiers could not see the sights or the enemy at night. They could only point and fire in the direction of muzzle flashes, a technique that is rarely successful beyond 25 to 50 meters. Battlefield illumination in the form of flares was used to enhance the effectiveness of weapons. Night vision and thermal sights, when present in sufficient quantities, can significantly alter the equation. The weight, bulk, and expense of these sights, however, have limited the percentage of troops able to bring them to the fight. An enemy who is deficient in night vision equipment can counter much of our advantage by conducting illuminated night operations. The DOS's tritium-illuminated reticle can engage muzzle flashes in total darkness, and its light-gathering capability can extend effectiveness under any available illumination, from flares to starlight reflecting off snow.

The Rangers have found that, in a supported position, it is possible to fire the DOS accurately while wearing a head-mounted AN/PVS-14 pocket scope. Night vision goggles and the active PAQ-4/PEQ-2 IR aiming lasers offer many advantages if the enemy does not have significant amounts of night vision equipment. The M4's Picatinny rail allows

RANGE IN METERS		TARGET TYPE	
0-100m	30-40%	Point	20-25%
0-200m	65-75%	Groups, sources of fire or danger	55-60%
0-300m	75-85%	Other (buildings, vehicles)	20-25%
0-400m	85-95%		
FIRING POSITIONS		LIGHT CONDITIONS	
Prone w/wo cover or support	25-30%	Day	50%
Standing stationary position	25-30%	Night	30%
Running, walking	40-45%	Dawn/Dusk	20%
Moving vehicles	5-10%	FIRING MODES	
		Aimed Semi-automatic	20-25%
		Aimed full-auto	20-25%
		Off-hand/point shooting	50-60%

Percentages of engagements that occur under stated conditions.

the dismounting and remounting of the DOS and new mini night vision sight AN/PVS-17 MNVS or PVS-4 while retaining zero.

The 5.56mm M855 fired from the M4/M4A1 carbine is capable of penetrating fabric body armor and steel helmets out to 600 meters and inflicting casualties out to about 800 meters, which is well beyond normal engagement ranges. The limiting factor at the longer ranges is the ammunition's accuracy, not its power. When fired from the M4A1 Carbine, the M855 ammunition will group within a respectable 10 to 17 inches at 600 meters. Since the average man is 19 inches wide, a well-aimed shot can be lethal at this range.

The DOS is intended to increase the soldier's ability to detect and identify targets, and detecting and identifying targets can improve his ability to observe and acquire information. As the operational squad performs the secondary mission of collecting and reporting battlefield intelligence, the commander can act, instead of reacting, on the basis of accurate accounting and description of the opposing force's strength, equipment, and location. When the sharpshooter sees or suspects a target, he uses the DOS for a detailed view of the target area. (The scope should not be used to search the area, because its narrow field of view compares to the eye alone, and its magnification can cause eye fatigue.) A soldier must always be aware of his surroundings and take nothing for granted. He must cue on a hint of movement, a flash, a puff of smoke, or a vague feeling that something doesn't look right.

In the attack, machineguns and squad automatic weapons provide suppressive fire to fix the enemy and degrade the effectiveness of his fire, allowing friendly forces to maneuver to a position from which they can put decisive fire onto the enemy. Suppression must occur over the required time. Suppression cannot be achieved by massed fire in the general direction of the enemy, because this requires unsupportable amounts of ammunition. Supporting sharpshooters, on the other hand, can maintain a high volume of precision fire on firing apertures and detect smoke flashes from machineguns

or rocket-propelled grenades, or even individual rifles. Instead of just firing at the objective and adding their fire to the rain of machinegun bullets, they can locate and engage point targets not apparent to the shooters with iron sights or the close combat optic. Hitting every enemy soldier who exposes himself to fire is far more suppressive than a few more bullets coming in his general direction. Attacking troops may be forced to begin an assault from as much as 400 meters out, which could require a lot of machinegun and mortar ammunition, especially with light infantry. Precision suppression from a platoon's three to six sharpshooters would allow the machineguns to conserve ammunition and increase their fire during the critical last 100 meters. As the attacking element closes on the enemy position, mortars, machineguns, grenade launchers, and riflemen of the fire support element must shift or cease firing to prevent fratricide. The sharpshooters' enhanced ability to identify and hit targets, however, would allow them to continue to fire in support of the assault.

Sharpshooters and U.S. Snipers

The sharpshooter concept supports and complements the sniper concept; it does not compete with snipers or in any way replace them. Sharpshooters basically use the issued infantry rifle and ammunition while snipers use a more powerful and accurate long-range weapon. Snipers require special selection and training; sharpshooters require only high proficiency in the fundamental marksmanship techniques. Snipers can make head shots at 600 meters and body shots at 800 to 1200 meters. Snipers are at their greatest tactical advantage when they engage targets from beyond 500 meters. Sharpshooters should routinely be able to make head shots at 200 meters, hit F-type targets at 300 meters, and hit E-type targets at 500 meters.

Squad sharpshooters offer a base from which to later draw candidates for training as company or battalion snipers. Sharpshooters share some high-priority targets with snipers, focusing on leaders, radio operators, other snipers, or heavy weapons crews. They don't have the range or power to address stand-off materiel targets such as radars or missiles. The infantry's employment of snipers, which is still evolving, has considered the sniper another supporting weapon that moves with the formation and is called upon as a situation presents itself, much as leaders would call to bring up the machinegun, rocket launcher, flame thrower, or engineer support.

Combat studies have shown that in this role snipers make a significant contribution only during the initial maneuvering in a meeting engagement or assault. Their contribution in the defense is the highest during lulls—engaging enemy patrols, harassing enemy observation posts and forces maneuvering at long range. During the assault phase of the attack or defense, bolt-action rifles and high-power optics have limited their contribution—thus leading to the sniper's on-again, off-again status with the infantry. Special Operations units and the Marine Corps tend to employ snipers more independently. Accompanying elements are often there to support sending the sniper mission. Snipers are sent out to

hunt appropriate targets where the stalk and the hide are as important as marksmanship skills. The sharpshooter is more compatible with the traditional infantry supporting role and is neither trained nor equipped for independent employment.

The snipers focus on the precision medium- and long-range engagement of priority targets and are usually employed at 3 to 9 per battalion for a one-shot, one kill. The sharpshooter concept would create 27 to 81 sharpshooters per battalion and provide a larger volume of precision short-range and enhanced medium-range fire against targets of opportunity. Snipers hunt priority targets, while sharpshooters can also engage these same priority targets, as they see the opportunity while maneuvering and firing as part of the squad.

There is some question whether 3 to 9 snipers per battalion can produce tactically significant results. Just increasing the number of snipers probably cannot be supported with the additional highly specialized selection, training, equipment, and sustainment requirements. But the addition of 27 to 81 sharpshooters would be a powerful combat multiplier and have a significant effect. This concept would be sustainable because it uses the standard weapon and ammunition and the expert level marksman created in the course of normal rifle marksmanship training.

Sharpshooters against Enemy Snipers

Field Manual (FM) 90-10-1, *An Infantryman's Guide to Combat In Built-Up Areas*, Appendix J, gives an excellent definition of enemy sniper threat levels. The classification of sniper threats is based on the soldier's skill level as a shooter/stalker and the range and accuracy of the system with which he is equipped, including weapon, ammunition, and optics.

An enemy *expert professional sniper* is specially selected and trained; he is equipped with an extremely accurate scope-mounted sniper rifle; and he engages targets from beyond effective small arms ranges (300 to 1500 meters). Against this threat, a squad sharpshooter would be clearly overmatched. The best answer to this threat is another sniper who is better trained, better equipped—with a flatter-shooting, more accurate rifle and better target acquisition and fire control equipment. The professional sniper can also be overmatched with direct-fire systems, such as the Bradley or the M1A1 tank with its thermal imager and precision 120mm gun, both of which are invulnerable to sniper fire. But even professional snipers are vulnerable in situations where they have lost the initiative. The squad sharpshooter can be effective against professional snipers, ambushing them as they move into or flee positions, and during chance contacts at ranges of less than 200 meters, where the high-power optics, slow rate of fire, and small size of the team even put the professional sniper at a disadvantage.

The next level of enemy shooter, the *trained marksman*, is an infantryman who is an above average marksman with good fieldcraft and usually equipped with the standard rifle, or possibly an enhanced rifle such as the 7.62X54R SVD. Trained marksmen are employed singly or in pairs to create confusion, inflict casualties, harass, and disrupt operations.

They are an economy of force asset employed with flank or rear guards or covering forces. In the defense, they can be employed on the perimeter or with outposts to provide warning and disrupt approaching soldiers by forcing them to deploy early, hitting them in attack positions, protecting obstacles. In stalemate or siege conditions, they focus on inflicting casualties, limiting movement, lowering morale, and supporting both reconnaissance and counterreconnaissance efforts. They engage the same priority personnel targets a sniper engages. They are employed with supporting weapons such as machineguns to increase the effectiveness of suppressive fire. In the attack, they attempt to eliminate priority targets in centers of resistance, holding up movement to a position where a close assault can be launched. Unlike a sniper rifle, the trained marksman's weapon has not been so specialized as to put him at a disadvantage in close combat. This is similar to the concept of the sharpshooter. Sniping by these marksmen is something that has evolved as an ad hoc arrangement during recent conflicts such as Grozny, and a trained American squad sharpshooter should be able to deal effectively with them as well.

The squad sharpshooter concept, therefore, is an attempt to exploit the lessons learned and formalize the concept in doctrine, training, organization, and equipment. A U.S. sharpshooter would be at the top of this class in quantity and quality. Combined with our snipers, squad sharpshooters could largely neutralize the threat of enemy marksmen and be a force multiplier in all dismounted operations.

The lowest level of enemy sniping is carried out by *civilian irregular snipers*. Although these snipers usually lack formal training, they may have years of experience in the long-smoldering conflicts around the world. They may use a standard rifle or even a scope-sighted hunting rifle. They usually engage targets of opportunity and are loosely coordinated with enemy combat operations. They often do not wear uniforms or carry their weapons openly, which makes them difficult to distinguish from the civilian population. This threat has confronted the infantry and cost us casualties from Vietnam to Somalia. A U.S. squad sharpshooter would have a overmatching capability against civilian irregular snipers in terms of both training and equipment.

A well-trained soldier who can fully exploit the inherent accuracy of his M16A2 rifle or M4 carbine and DOS, would be a versatile supporting asset to the commander. The squad sharpshooter could be implemented quickly, cheaply, and in numbers that would offer a significant tactical advantage. And such an advantage can pay dividends in terms of lives saved and battles won in the next conflict.

Lieutenant Colonel Michael R. Harris, U.S. Army, retired, served in operational units in Panama and at Fort Bragg and in combat development activities at Fort Benning, Fort Lewis, and Fort Bragg. During Operation *Desert Storm*, he was assigned to Special Operations Command Central in Kuwait. He holds a master's degree from the Florida Institute of Technology.



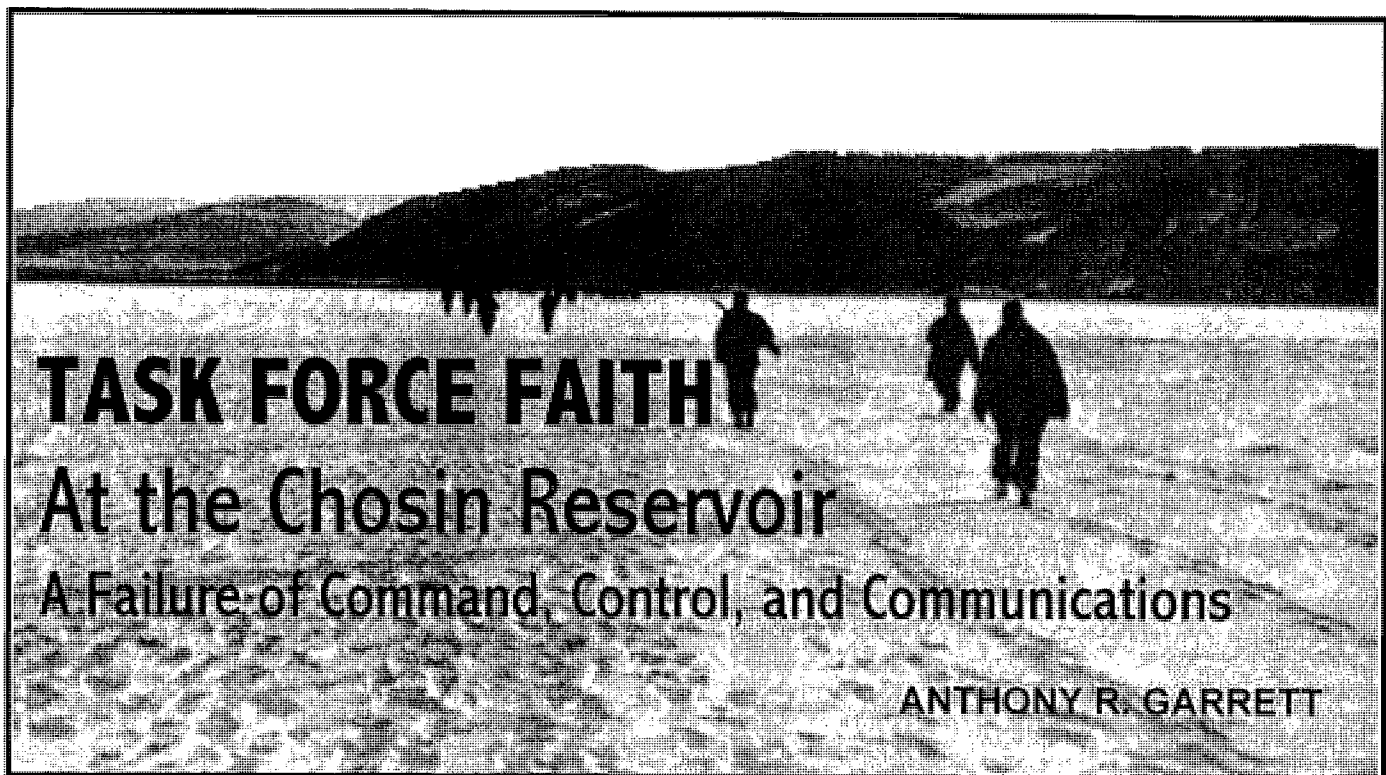

TASK FORCE FAITH

At the Chosin Reservoir

A Failure of Command, Control, and Communications

ANTHONY R. GARRETT

The defeat of Task Force Faith (originally Task Force MacLean) on the eastern shore of the Chosin Reservoir in late November 1950 was one of the worst disasters for the U.S. Army in Korea. Could it have been prevented? At least to some extent, the fate of the task force could certainly have been different, given that disasters seldom occur spontaneously; rather they result from a series of events whose cumulative result leads to catastrophe. This article will present the proposition that the defeat of Task Force Faith was due, in large part, to an inadequate command and control structure as well as ineffective and inadequate communications.

The Strategic Setting

Following the success of the U.S. X Corps at Inchon and the Eighth Army breakout from the Pusan perimeter, Lieutenant General Walton H. Walker and his staff developed a plan for pursuing the North Korean Army across the 38th parallel. The overriding intent was to destroy the remnants of the North Korean People's Army (NKPA) before it could gain a sanctuary in Manchuria. An integral part of this plan was the incorporation of X Corps into Eighth Army, thus establishing a unified command structure for future operations. Unfortunately, no one had consulted General Douglas MacArthur.

MacArthur's plan called for X Corps to remain an independent command under Lieutenant General Edward M. Almond, who would report directly to him. X Corps, under MacArthur's plan, was to withdraw from the battlefield, board ships at Inchon and Pusan, and conduct an amphibious landing on the east coast of North Korea at Wonsan. From Wonsan, X Corps would attack northwest across the peninsula to seize Pyongyang, while the Eighth Army would attack north across the 38th parallel toward Pyongyang to create a double envelopment.

Upon learning of MacArthur's plan, General J. Lawton Collins, the Army Chief of Staff, expressed concern over the command arrangements that left X Corps independent of Eighth Army. But having been proven wrong about the feasibility of the Inchon landing, the Joint Chiefs of Staff were reluctant to voice their objections, and, on September 29, cabled their approval of MacArthur's plan. On October 2, MacArthur issued orders for the redeployment of Eighth Army and X Corps for the invasion of North Korea.

As events unfolded, it became apparent that the Eighth Army would capture Pyongyang ahead of schedule and would not need X Corps support. Accordingly, on November 16, MacArthur changed the X Corps mission. Now, the corps would orient its attack north toward the North Korean-Chinese border. When it reached the Changjin Reservoir (best known by its Japanese name, Chosin), the corps was to turn west to intersect a main supply road that ran south from the Yalu River into the Eighth Army sector.

On November 17, the corps staff presented a plan to Almond for approval. Almond made several modifications to the plan and approved it, with one significant change—the 7th Infantry Division would provide a regimental size task force to move north on the east side of the Chosin Reservoir. This would permit the 1st Marine Division to withdraw the 5th Marine Regiment from that side of the reservoir and concentrate the division for the attack on the west side.

Organizing and Deploying the Task Force

The corps operations plan issued on November 25 called for the regimental task force to be in position on the east side of the reservoir no later than noon on November 26. In view of the current disposition of the 7th Division regiments, this was a monumental task. Beginning on October 29, the division had landed at Iwon, 150 miles north of Wonsan. The

first regiment to land, the 17th Infantry, led the advance towards the Yalu. The next regiment to land was the 31st Infantry followed by the 32d Infantry, which went into bivouac northeast of Hamhung. The requirement to meet the timetable forced Major General David G. Barr, 7th Division commander, to form an ad hoc regimental task force consisting of units that had no previous experience working together. Colonel Allan D. MacLean commanded the 31st Regimental Combat Team (RCT), which consisted of the 1st and 2d Battalions, 31st Infantry; the 1st Battalion, 32d Infantry (commanded by Lieutenant Colonel Don C. Faith, Jr.); the 31st Tank Company; the 57th Field Artillery Battalion; and Battery D, 15th Antiaircraft Artillery Automatic Weapons Battalion.

The 1st Battalion, 32d Infantry—because of its proximity—was the first unit to arrive at the Chosin Reservoir on November 25, and immediately occupied the positions vacated by the 5th Marine Regiment. The 3d Battalion, 31st Infantry, arrived the following day and established a perimeter two miles south of Faith's unit. Due to delays along the main supply route, the 2d Battalion, 31st Infantry, never reached the reservoir. Consequently, the task force never reached regimental strength.

On November 27-28, Faith's battalion encountered a roadblock just across the narrow expanse of ice from 3d Battalion and began taking fire. Colonel MacLean—convinced that the fire was coming from his own forces—started over the ice to stop the shooting. Instead, he walked into the hands of the Chinese. He was hit at least four times as he crossed, and a later search of the area uncovered no trace of him. With no senior officer present, Colonel Faith assumed

command of the two infantry battalions and the artillery, designating the consolidated units Task Force Faith.

Task Force Faith at the Chosin Reservoir

Task Force Faith fought the Chinese Communist Forces (CCF) at the reservoir from November 27 to December 2. With each CCF attack, the task force experienced losses in key leader positions.

Although a detailed discussion of the numerous engagements is outside the scope of this article, an examination of certain key events will illustrate the fundamental reasons for the disaster that befell the unit.

The task force arrived at the reservoir without adequate communications to support a command and control structure. The one vehicle-mounted radio, an SCR-193, was at the 31st RCT command post (CP), and it failed on November 27, never to become operational again. After November 28th neither the forward infantry battalions nor the field artillery battalion could communicate with the 31st RCT CP, and this problem extended down to the company command level. Although wire communications within the task force were effective, once the battalion started moving, the companies could not establish radio contact with the battalion CP. Ordinarily, using messengers could have offset this situation, but the soldiers' ability to walk or run was hindered by the bulky issued cold-weather footgear, or shoe-pacs. This lack of runners proved disastrous during the breakout attempt when the task force became fragmented, and led to a loss of command and control.

Finally, on November 29, General Barr placed Faith's task force under the operational command and control of the 1st Marine Division, operating on the west side of the reservoir. Unfortunately, the task force never established communications with the Marine division CP, even though a Marine air liaison officer with the task force was in constant contact with the Marine close air support aircraft.

Normally, an effective command and control structure and implementing instructions can overcome, or at least mitigate, communications system failures. At the Chosin Reservoir a lack of such procedures and a failure to coordinate plans compounded the communications failures. Following Colonel MacLean's disappearance, responsibility for the operation fell upon Lieutenant Colonel Faith.

On December 1, Faith decided to attempt a breakout rather than risk certain destruction in another CCF night attack. Planning a breakout from encirclement requires detailed coordination with all elements. The planning and coordination were hastily done, and certain units did not learn of the breakout until they noticed that adjacent units were moving out. Fundamentally, the plan should have provided the flexibility to respond to anticipated events. Given the demonstrated Chinese preference for night fighting, the plan should have addressed actions after dark. Yet the plan did not envision conducting the breakout at night, even though it started with only four hours of daylight remaining. As events unfolded, the breakout continued into the night, at which point the CCF attacked the task forces at various points. Lacking a comprehensive plan and subordinate lead-

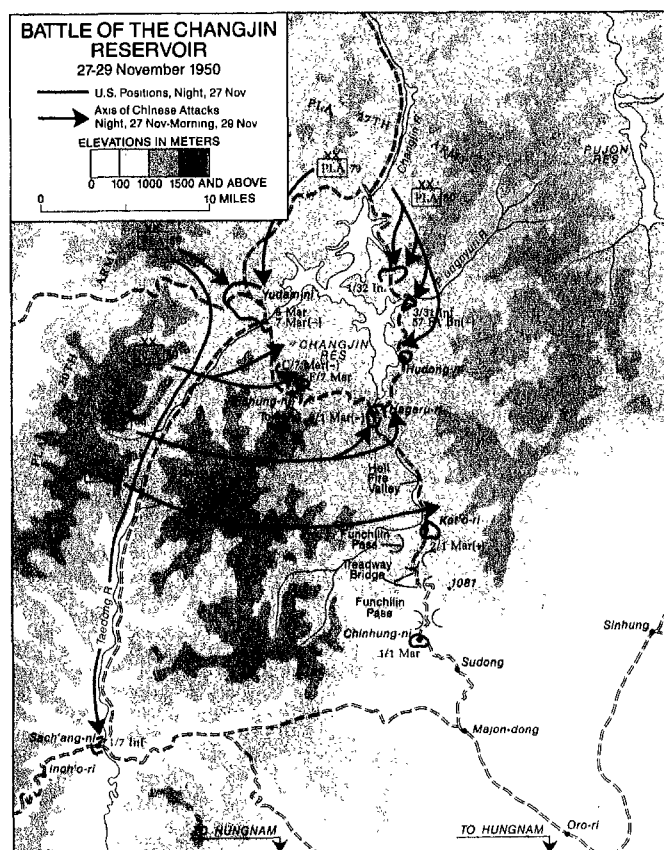

ers to provide direction, the soldiers were reluctant to counterattack the Chinese. Attempting to restore order through personal example, Faith led an attack on a roadblock at Hill 1221. In the process, he suffered a mortal wound. Virtually leaderless, the task force began to disintegrate into small groups. In the words of a member of Task Force Faith, "After Colonel Faith was killed, it was everyone for himself. The chain of command disappeared. Some men sat down and refused to move."

The other area of concern focuses on the failure of X Corps to replace key leaders lost during CCF attacks and formulate a plan for withdrawing the task force from the reservoir. General Almond had learned of Colonel MacLean's disappearance on November 30. In view of the precarious situation, the X Corps commander should have become more personally involved in restoring the chain of command. There was no Army officer senior to Faith in the area and it is doubtful whether General Almond would have appointed a Marine officer to command the task force, although there was historical precedent for such a decision (in World War I the U.S. Army 2d Infantry Division was commanded by a Marine officer).

There was, however, another option. Brigadier General Henry I. Hodes, the assistant division commander of the 7th Infantry Division, had visited Faith at the reservoir on November 26 and was familiar with the situation. Appointing Hodes to command the task force would have had a tremendous effect on the morale of the unit. More important, it would have allowed Faith to plan the breakout for his battalion while Hodes orchestrated the overall concept of operation. In addition, General Almond should have provided the task force with combat-experienced platoon leaders to replace the casualties at small-unit level. The absence of these leaders was sorely felt during the breakout attempt.

Finally, the X Corps should have developed a plan to support the withdrawal of Task Force Faith. Almond, Barr, Hodes and Major General Oliver P. Smith (the 1st Marine Division commander) met on November 30 to discuss the situation, but made no decisions concerning the resupply of ammunition, fuel, and supplies, or the replacement of key leaders. Furthermore, they failed to reach agreement on how to reestablish communications with Faith even though General Smith exercised command and control over the task force. In the absence of support and guidance, Task Force Faith attempted to extricate itself from the reservoir with the means at hand. In the end, 1,050 survivors of the original 2,500 member RCT reached the 1st Marine Division CP at Hagaru-ri. Of these, only 385 were able-bodied soldiers.

What did the survivors of Task Force Faith conclude about their performance at the Chosin Reservoir? A Major Curtis, the operations officer for the 1st Battalion, 32d Infantry, said, "The plan did not work and the mission failed because control was lost from the outset—and, in fact, the rifle elements failed to provide flank and rear security. . . . Our main problem was maintaining control of the troops under very trying circumstances."

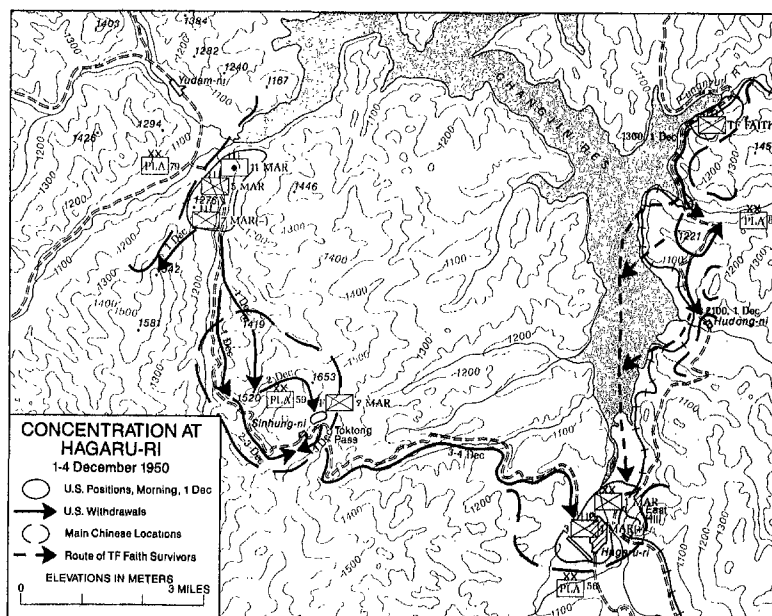

Ironically, the fate of Task Force Faith was not a foregone conclusion. The fundamental shortcomings that contributed to the defeat were failures to plan and implement an effective command and control structure that could function even without a communications system. The disintegration of the task force underscores the importance of the commander's intent. If Faith had articulated his intent within the framework of a simple plan, subordinate leaders would have been able to execute it in the absence of further orders once he was mortally wounded.

The actions of surviving subordinate leaders also emphasize the importance of training leaders to act independently. As a staff sergeant observed, the unit became paralyzed when the commander was killed. If subordinate leaders had been trained to think and act independently within the context of the commander's intent, the outcome at the Chosin Reservoir might have been markedly different.

EDITOR'S NOTE: A few years ago, the phrase "no more Task Force Smiths" made the rounds, but this was not the only such disaster to befall U.S. forces in the Korean War. As we review the lessons of Task Force Faith, we must examine the decisions and circumstances leading to its defeat in light of today's Army and units. By a critical scrutiny of today's training and readiness, we can go a long way toward ensuring that U.S. forces on future battlefields do not suffer the same needless casualties that crippled Task Force Faith. Our men fought as well as they could under unforeseeably difficult circumstances, but factors beyond their control left them at the mercy of the winter and an implacable enemy.

Anthony R. Garrett is a retired infantry officer with more than 25 years of service. He served as a company commander in the 2d Infantry Division and as Battalion S-3, 2d Battalion, 22nd Infantry, 10th Mountain Division. He has held staff assignments at the Department of the Army and The Joint Staff. He is a graduate of Georgetown University and holds a master's degree from the Army Command and General Staff College. He is currently a Senior Analyst supporting the Assistant Deputy Chief of Staff for Operations and Plans, Force Development, Headquarters, Department of the Army. His work has appeared previously in *Infantry* magazine.

TRAINING NOTES



Tough Training in Tough Times Infantry Officer Candidate School—1942

FROM AN INFANTRY MAGAZINE INTERVIEW WITH
COLONEL ROBERT B. NETT, U.S. Army, Retired

Editor's Note: Today's graduates of Fort Benning's Officer Candidate School (OCS) can look back with pride on the legacy of their predecessors, many of whom served with distinction in World War II. I have asked one of those distinguished graduates, Colonel (Retired) Robert B. Nett, to comment on the value of the training he received as an officer candidate in 1942.

Following graduation, he returned to the Pacific Theater, where his courage and leadership enabled him to successfully lead his platoon against a stubborn and determined Japanese adversary. Then Lieutenant Nett was awarded the Medal of Honor for heroism on Leyte in December 1944.

Here is the OCS experience, as recounted by Colonel Nett.

The shock of Officer Candidate School (OCS) at Fort Benning seemed to compound with each day: Up at about 5:30 each morning, 30 minutes of rigorous physical training (PT), followed by reveille formation at 6:00. During calisthenics, everyone in the company was to do pushups until we were all flat on our faces. We were taught by a First Lieutenant who looked

like a professional football player and had been given a direct commission to come in and teach calisthenics to officer candidates. He would go through the routines, and as soon as we were all flat on our faces, he would call us to attention and double-time us around the field. Finally, he would dismiss us with a few comments about how sorry we were, how out of shape we were, and what we needed to do to get in condition before the next session, which was bright and early the next morning!

The mess hall opened immediately after reveille formation, and after breakfast we returned to our little hutment in the remote Harmony Church area of the sprawling Army post. These huts were made of Celotex, a fiberboard made from sugar cane fiber and covered with tarpaper; the floors were pure sand. There were a total of eight officer candidates per hut. We commonly referred to our huts as "tarpaper shacks."

Each structure had a small roof extension that protruded out over the door about two feet and a small porch made in the form of a foot scraper, a series of boards about one inch apart on edge so that we could scrape our boots before we went into the hut. To the right of the doorway was a rack holding a couple of

brooms, which we used to sweep the sand smooth as we worked our way out in the morning. (The sand had to be cleaned free of footprints each time we left.)

Our transportation to the field was called a "Cattle Car." This was a long trailer previously used for horse cavalry. It had benches down each side and a third one down the middle, and could hold about 50 people, all in full combat gear. It wasn't unusual for the Tactical Officer to tell everyone to stand up and move back so that another 10 or 20 men could be fitted in. It then became a challenge to sit down, and usually someone ended up on top of you. It was even more of a challenge when you consider that we were all armed with rifles that could get tangled up in the mass of legs, arms, and other equipment.

Classes usually started at 7:00 in the morning. We had to draw our weapons from the weapons room, and clean them if necessary. Next, we headed to the training site. Each period of training began with an explanation, in which the instructor gave us a detailed description of the problem or task we were assigned. The second part was a demonstration, usually given by schooled

troops. We were next given or put through a practical exercise where we followed the same procedures that had been demonstrated to us. The last part was the critique phase, where we were assembled and told what we did or did not do towards accomplishing what we were assigned. Most instruction was for a four-hour period.

We normally ate in the field, using the mess kits we carried in the combat packs on our backs. We were occasionally provided with utensils and paper plates. The meals tasted very good to me, after subsisting on C-rations week after week in the Pacific. When we had a ten-minute break, the command was given: "Quick time off the stands! Double time, post!" which meant to get off the stands quickly but in a proper manner so no one would get hurt, and then double time over to our platoon leader. We would then have calisthenics for five minutes. After this, we were given the rest of the period for personal time, to ask questions, and to do whatever else was needed. When the whistle blew, we had to move back rapidly to the stands and be ready to go when instruction began again.

We only had box toilets and no running water except over in the shower room—a small room with about ten shower heads—and we could go there to do our showering and cleaning up. Quite frequently, we would find ourselves there at 11:00 or 12:00 o'clock at night, studying field manuals. This was because we often had instruction until very late and then were given reading assignments for the next day. After we went back to our huts, our weapons had to be thoroughly cleaned, inspected, oiled, and put back in the racks for the next day. This all had to be done by the time the call to quarters was sounded.

About one-third of our training was at night. This entailed everything from a night compass course to night attack and patrolling, and all of the different rudiments of night warfare. Those of us who had already been in combat knew how important this instruction was. During my 8½ months in the Pacific Theater, I had learned how skilled the Japanese were at night operations, and so I paid particular attention to this and

other blocks of instruction, and urged my peers to do the same. I learned a great deal that helped considerably upon my return to the Pacific after graduation. We learned many helpful tips, both from our instructors and from classmates who were already combat veterans.

Since the Japanese operated frequently at night, we employed a number of field expedients to deny them the element of surprise. At a time when both barbed and concertina wire were in short supply, we often strung commo wire parallel to and in front of our positions and hung C-ration cans with a few pebbles in them as early warning of enemy movement to our front, sides, and rear. Lacking anything comparable to today's Claymore antipersonnel mines, we also had to improvise, using quarter-pound blocks of TNT.

One of my first periods of instruction was Map Reading. I considered myself talented in this area and looked forward to it. We were taken in groups of three on a truck with a tarpaulin pulled down over the back. We had no idea where we were going.

We were dropped off by numbers and our mission was, first, to find out where we were. We were given a photo map of the area and it was up to us to determine how to get to a certain point. We noticed on the map that we were by a hard-surfaced road that was covered with crushed stone and clay mixed together. I suggested to my group that one person go up the road for ten minutes and one person go down the road for ten minutes and see if we could find a bridge or culvert that we could compare to something on the map. This map was a series of photos put together with a grid superimposed on it. Sure enough, one of the men who was sent out came back in about eight minutes and reported a bridge to our north. We moved up to the bridge and started identifying terrain features, with the help of a little moonlight. The leader of our group took out his compass and shot an azimuth. We started walking on that azimuth, and my mission was to count off every 100 yards. I took a handful of gravel and each time we reached 100 yards, I stuck one pebble in my pocket.

We had gone about 1,000 yards when he said we should almost be there. Sure enough, when we went a little further, there was Victory Pond. (Of course, we didn't know it was Victory Pond at the time but it was a pond and we looked for it on our map.) At this point I realized that we had been traveling on a back azimuth. The compass man had looked at the wrong edge of the compass. I decided to take the map and study it further. Finally, I saw a little intermittent creek bed and pointed out that we should move down it, cross several fields, come out on a road, follow it a little way, and we should be where we were supposed to be. The group decided to go along with my suggestion. When we finally got to the road, we scouted it very carefully and—lo and behold—we found our reporting station. We reported in and the sergeant took our card and told us we were the first ones in! "How did you make it so fast?" he asked. The others looked at me with funny expressions as I said, "We're just experienced NCOs who know how to read a compass." He looked at us for a minute then told us, "Go down the road for about a mile and there'll be a truck waiting. You get in the truck and wait and when we get it filled, we'll take you in and there'll be coffee and doughnuts. You'll be able to relax and get a good night's sleep." We thanked him and moved off down the road. We fell asleep in the truck and I don't even remember its moving. We got to the company area and I woke the others and said, "We're home!"

The quality of land navigation instruction at Fort Benning was superb, and every leader—officer and enlisted—must be thoroughly familiar with using a map and compass. Without it, he cannot coordinate direct and indirect fires, effectively maneuver his unit, or conduct the logistical operations that will sustain the unit in combat.

The most intriguing courses, however, were the seven live-fires we conducted on problems ranging from a night relief to an attack on a fortified position. These were full-up operations that included flame weapons, shaped and satchel charges, hand grenades, and Bangalore torpedoes. This training in-

cluded mortar and artillery fires, and my class was unanimous in commending the artillery committee for the best instruction presented to us. They left us with complete confidence that we could direct indirect fires when and where they were needed. The value of this instruction was borne out some months later, on Leyte, when my 4.2-inch mortar observer was wounded and I had to direct my own mortar fires.

We had all levels of experience in our Officer Candidate platoon. We had some soldiers who had been in combat, some who had been overseas and had trained with the British, and others who had just completed basic training and a short leadership course. This made it quite a challenge for each individual, as well as those in charge of the live-fire problems. In spite of my combat experience, I was embarrassed at how much I had to learn, and as a result paid close attention to the heavy volume of information presented. Live fire was the name of the game, and what we learned about it in those grueling hours would pay dividends in terms of lives saved and objectives seized once we found ourselves in combat.

The curriculum was spelled out thoroughly and it became a six-days-a-week, in-the-field, exercise-after-exercise experience. One-third of that time would be at night in such courses as night attack or night patrolling with the prescribed equipment. Sunday was a day for church and administrative details. The one-hour schedule for church service was respected, and all attended. Upon returning to the company area, we were required to do all types of administrative work such as filling out and signing forms, filling out questionnaires pertaining to our security clearances, and similar activities. There was little or no free time except for that allowed for religious services.

One Sunday afternoon, we all went to the theater, and up on stage were the battalion commander and his staff officers. There was to be a formal dinner at the commander's home, and we were drilled on such courtesies as seating the ladies, saying Grace, passing the food, and properly using the silverware. At the entrance was to be a table with a

white tablecloth on which would be a silver tray. We were to place the name cards from our wallets on the tray—a card for each adult member of the family. Protocol called for us to do this without the commander or his wife seeing us.

The life of an officer candidate was as challenging in the cantonment area as in the field. I can remember standing in the pouring rain when this big six-foot two-inch tech sergeant would give us a speech that went something like this: "I don't give a damn if you have gotten a little wet. These weapons will be thoroughly cleaned. I will inspect them and then you will put a thin coat of oil on them and take them to the arms room. Do I make myself clear?" All this time, he was standing under the porch of one of the huts while we were out in the pouring rain, standing in the mud, in platoon formation! We couldn't wait to get in that hut and clean our weapons! It got to be a joke and we would hear others in the hut mimicking the tech sergeant as they were cleaning weapons.

As we moved on to the final phase of our training, we were given tactical training by three officers whom we referred to as "The Mad Majors." One had a bayonet scar across his cheek, from a wound received in World War I. I think they acquired their collective nickname because they believed so deeply in what they were teaching that they often got emotional. Being officer candidates, we often had to find something smart to say about instructors—but never to their faces, of course.

The Weapons Department of the Infantry School did a fine job. We went through every weapon in the infantry. We not only detail-stripped it, assembled and reassembled it, but also were taken on the range and fired a familiarization course followed by a record course. This included weapons such as the 37mm antitank weapon right up to the 60mm and 81mm mortars. We needed every extra minute to cover all this subject matter. Weather was no impediment to our tight schedule. The most we could expect was a set of bleachers with a cover on it so we could listen to the instruction and take notes.

Due to the urgency of the war effort, it was out of the question for us to have a large graduation ceremony. There was no time for a class book, and all we could hope for was a roster and a little folder for a memento. We were Class 136 and we graduated December 26, 1942. I remember that our class went to Theater Number 3 in Harmony Church and were seated in alphabetical order. When the first sergeant gave the word, he would tell each individual to stand and face to the right and when he finished calling the row, we would move out to the stage and line up on one side. When the battalion adjutant called our names, we walked smartly across the stage, saluted, shook hands with the assistant commandant, and received our diplomas. We then went over and shook hands with the battalion commander, company commander, and tactical officers, and then returned to our seats.

Not all of my classmates were able to graduate with their peers. In my row at graduation, for example, there were two candidates whose names were not called. They had on their uniforms and were ready to go, but it was not to be. While we were engaged in training, if a candidate was to be eliminated from the course for one reason or another, a jeep would drive up with the message that he was to report to the company commander. When we returned from the field, the man and all of his equipment would have vanished.

Most of us, however, were able to complete the course successfully and graduate. After the ceremony, we marched outside, gave three cheers, and put on our rank. Next, we marched back to the company area where we were given pay and allowances and our orders on where to report. I was ordered to the 77th Infantry Division at Fort Jackson, South Carolina. We then took buses into town, either to the bus station or the train depot. While I was getting ready to board the train for Fort Jackson after getting my ticket, I went to the restroom, where I saw one of my fellow candidates putting on first lieutenant bars. I asked, "My, don't you think that's inappropriate? It's gonna be a while before you make first lieu-

tenant.” He smiled and said, “Nett, in each class, there’s an FBI agent, and he goes through the class and monitors the character of all the candidates. This is the third class that I’ve graduated with. I’m going home on a 10-day leave, and I’ve been a first lieutenant for over a year!” I shook his hand and congratulated him, then went out and got on my train.

Sitting on the train, I found myself thinking back on all the trying times of the school, but I also realized that I had been very well prepared for all of the duties I was about to take on. I knew

that I had also been taught those qualities which are essential for a good leader and the successful running of a platoon. We had also been taught discipline. Each of us was so disciplined that when the first sergeant told us to walk out the side door after graduation, we did it without question. As we came out, there he was, giving us our first salute as officers and collecting his dollar. (It was tradition to give a dollar to the first individual to salute you.) We were all very happy to give him that dollar, and we realized that we owed him a lot more than that.

When the train finally arrived and unloaded, our main concern was finding Fort Jackson. A representative was on hand to direct us to buses, which took us directly to the headquarters building. In the basement, we found the adjutant general staff officer, who took charge. A new life was beginning. I walked proudly, aware of the gold bars on my shoulders. Looking back, I will always remember the thrill of receiving my diploma, standing, and raising my right hand, and taking my oath as a commissioned officer in the United States Army.

The Rifle Company

Cohesion through Competition

CAPTAIN THOMAS H. GREER

Every future company commander agonizes over his command philosophy—the principal focus and direction he wants his unit to take during his tenure. Although few of these philosophies contain original thought, all are geared to develop the same thing—warriors who are capable of closing with and destroying the enemy.

In Korea near the demilitarized zone, Company A, 1st Battalion, 506th Infantry, focused on three simple but essential core areas—weaponry, battle drills, and leader training—with a strong emphasis on physical toughness and foot marching. This focus was based on the idea that the next war in Korea is likely to mirror the one in the early 1950s: The terrain has not changed; the climate has not changed; and the determination and psychological will of the enemy must be assumed to be unchanged as well. It will be a close fight in rugged, compartmentalized terrain where the difference between winning and taking second place will be the physical fitness of the infantryman and his ability to kill

what he shoots at on the next high ground over.

Every member knew the collective focus of the unit, which made it easier for even the youngest private to understand the end state of any training event. This also provided the foundation and baseline guidance for training events the sergeants and platoon leaders were tasked to develop. Before they went off in a corner to develop the training objectives, review the task, conditions, and standards, and coordinate resources, they had to understand how the event related to the company's focus. Before each brigade quarterly training brief, the commander reviewed the schedule for company training time—the time he owned to use as he saw fit—and templated these times with the company focus. The hard rule was that each prospective event had to contain two of the three areas before it could be considered “high-payoff training” and be tasked out to the action sergeant or platoon leader. This is standard stuff for company commanders and easily mastered after

the first quarter or two in the job.

Most units conduct high-payoff training in the bedrock skills of the infantry squad and platoon. But how can the commander get out of his soldiers that extra 10 percent that will be required when the shots are for real? What is that key ingredient in the best of infantry rifle companies? What makes the soldiers of a company truly believe in themselves as a unit, or have that genuine feeling of esprit-de-corps and cohesiveness? The answer is *competition*.

Competition is a concept that most infantry soldiers have grown up with—whether in little league baseball, sandlot football, or high school wrestling—and most are not ready to give it up. The feeling of victory, the disappointment of defeat, or the thrill and satisfaction gained through exerting maximum effort against a worthy opponent toward something important—all of these are hallmarks of the infantry soldier and a must in training. Infantrymen are winners by nature. They need to feel a

sense of accomplishment, receive recognition from their superiors, and be rewarded for exceptional effort and performance. They also need to know what it is like to give their all and still come up short, which can spark healthy discussion in a unit.

Korea can be a tough place to serve, or it can be a 12-month course in infantry tactics techniques, and procedures. Of course, individual attitudes determine the 12-month course, but the company commander can make a major difference in changing those attitudes and developing cohesion through competition.

In Company A, the commander mapped out all of the various training events he could influence in a given quarter, and then worked in some competitive events to build the esprit and cohesion the company would need to fight a hardened enemy who is always only a few kilometers away.

The initial focus was on the M60 machinegun crews and squads. We viewed these groups as our company muscle and wanted them to feel they were chosen for the job on the basis of performance instead of "arrival in country" date. Once a quarter we scheduled a two-day event to recognize the top individual M60 crew and weapons squad. We developed a list of 10 events that were physically and mentally taxing; if they were not difficult or demanding enough, the soldiers would be the first to voice their displeasure. Graders were pooled from the rifle squad leaders, and no grader was allowed to evaluate or test the squad or crew from his own platoon.

The commander and first sergeant served as monitors on each event and participated in the physical events to share the discomfort with the troops and keep them motivated throughout the long two days—but mostly to evaluate the collective will, competitive spirit, and leadership skills. The scoring of events was weighted on the basis of the difficulty of the event, physical demands, or skill required. We always weighted the foot march and live fire portion more heavily. When possible, we staggered physical and mental events to ensure that each soldier had

enough time to rest and drink enough fluids.

The "Best" M60 crew/squad event changed slightly from one quarter to the next to keep the soldiers guessing and to provide variety. The typical two-day event started early in the morning with a four-event PT test (pull-ups included), followed by personal hygiene and a quick breakfast before the 50-question written test was administered. The test questions were taken directly from Field Manual (FM) 23-67, *Machinegun 7.62mm, M60*, and each question required several answers to be entirely correct.

Next, the crews put on full battle gear, rucksacks, helmets, and load-bearing vests, drew the entire M60 weapon system and personal weapons,

Competition is a concept that most infantry soldiers have grown up with—whether in little league baseball, sandlot football, or high school wrestling—and most are not ready to give it up.

and departed for the top of "Magic Mountain" on a timed foot march. Nicknamed "Magic Mountain" by the troops, and spoken of only with the utmost respect, this towering and majestic hilltop rises 400 feet from its base with numerous vehicle and foot access routes, all going up, of course. We tried to include the hilltop in as many competitive events as we could and once executed the foot march with full gear in military-oriented protective posture (MOPP) IV.

One of the more popular events was the combat run. The uniform consisted of kevlar helmet, weapon, load bearing vest, and protective mask, and the course required the soldiers to negotiate a ridge line leading to the peak of the mountain. Along the course, the crews had to react to various targets, followed by the standard transition fire. Once the gunner fired his iteration, the assistant gunner executed the same scenario with the gunner's zero, just as he would have

to do in combat. When enough ammunition was available, the ammunition bearer fired the 10-meter course for record. This was followed by a timed "shoot the log in half" drill, in which each crew had 200 rounds to shoot a railroad tie in half at the center as its ends rested horizontally on sandbags approximately six inches off the ground. The ammunition bearer had 90 rounds to help with his M16A2. The gunner would start with the first 100 rounds and then roll out of the way to allow the assistant gunner to fire the second 100 rounds. This event was timed, and the first crew to split the tie won. Second and third places were determined by the next two crews to split the tie. If three teams did not split the tie before their ammunition was expended, the commander and three weapons squad leaders determined the ranking on the basis of the amount of wood removed from the rear of the tie and the tightness of the shot group.

One of the greatest benefits from competition in the company was that the sergeants had to perform to standard and set the example in front of their men. It is a humbling experience for a 35-year-old staff sergeant—whose previous four years may have been spent working at range control back home—to be struggling to get up our favorite ridge line leading to the top of the mountain, while his men were carrying more weight than he was.

The youngest soldier is often temporarily forced into the role of the leader, having to motivate and encourage his squad leader because the clock is ticking and another gun crew or squad is passing them by. Competition is a great equalizer, and the leader who fails to prepare his men or himself will suffer professional embarrassment in front of his peers. The leader who fails to perform to standard during the competition will quickly lose his soldiers' support, and will be a liability to the entire unit in combat. It was very encouraging to see the change in attitudes after just the first competition. The gun crews and weapons squads now had something to focus their training on during the next quarter.

We wanted to ensure that the young

platoon leaders were not forgotten and that they also endured some of the same stress we were placing on their soldiers. Platoon Leader Jeopardy, a modified version of the television show, was designed to square off the platoon leaders simultaneously against each other. We mustered the company to watch its platoon leaders perform and display their knowledge of machinegun tactics and techniques. The simple fear of having their men lose confidence in them was enough to ensure that they used their preparation time wisely. This event was a great professional development tool for the commander. All the platoon leaders became "book smart" in employing the M60 before serving as range officers in charge or before a collective training event.

Young warriors like to see their names in the headlines, and they enjoy, as long as possible, the bragging rights that come with winning. We covered this by purchasing a large plaque to hang just inside the entrance to the mess hall—the one area that every member of the company passed by three times a day and that was easily seen by all visitors. The plaque was complete with a 10-inch plastic replica of the M60 machinegun and a dozen brass plates. After each competition, we had the winners' names, gun team number, and platoon engraved in one of the plates for all to see. After seeing the excitement and healthy competitiveness enjoyed by the weapons squads and the M60 crews, the rifle squads were itching to test themselves against each other for the right to call themselves the "Best" rifle squad in the company.

Because of the high overhead in training resources and time, we decided to execute this two-day event semiannually. The events were similar to the M60 competition, and the weapons squads provided graders and support personnel. We added to this event a night land navigation course that was designed by the platoon leaders on their off time and during morning PT hours. This was executed in fire team groups and in severe cold weather as low as -5 degrees wind-chill. Of course, the navigation point with the most value was on the very top of "Magic Moun-

tain." By the time the best rifle squad competition ended, each soldier had been up the mountain three times—once during the foot march, once during the combat run up the ridge, and finally during the night land navigation. Keeping the event results hidden from the participants throughout the two days was key to sustaining maximum effort from each individual.

Competition worked so well for the company that we began including a little of it in each training event. While executing room and building clearing battle drills at the live fire tire house, we developed a force-on-force scenario in which a downed Air Force pilot in North Korea was being held prisoner. The mission was to enter the building, clear the rooms, secure the black box and the pilot, and exfiltrate with all friendly personnel and precious cargo. This quick fragmentary order to the platoon leaders was all they needed to prepare a plan, brief their men, execute a few generic rehearsals and briefbacks, and be in the assault position. The scenario remained the same for each platoon, and the evaluation was done from the catwalk looking down under night vision goggles. The commander, first sergeant, fire support officer, and executive officer all evaluated from different positions on the catwalk and pooled their comments after each platoon iteration.

We came up with a short list of things to key on while evaluating each platoon: close quarter battle techniques and fundamentals, teamwork, accomplishment of the mission, leader control, and situational awareness. The rewards for this competition can be as simple as recognition by the commander and first sergeant in the company formation before foot marching back to camp, or it can be a three-day pass for the entire platoon.

Another event at the tire house was recognizing the shooter with the best understanding of and ability to perform the reflexive firing techniques and fundamentals required in an urban environment. After two days of firing the requisite reflexive firing static tables in accordance with various close quarter battle standing operating procedures,

the soldiers understood the importance of firing a controlled pair, or "double tap" at each target. As each fire team or squad conducted a live fire assault on single or multiple rooms, we kept track of each soldier's shot group. After the day's events, we had the top five soldiers with tightest shot groups throughout the day compete for the title of "best reflexive firer" in the company. Each soldier was required to enter the room and engage a target in his immediate sector of fire with a controlled pair. He then had to transition to three subsequent enemy targets as he collapsed his sector of fire and moved to his point of domination. Partially inflated balloons were placed on the targets as aiming points, helping the soldiers aim and giving them immediate feedback. Executing this event required only 40 rounds of 5.56mm ball ammunition and 15 minutes and gave every soldier something to strive for throughout the day.

While in garrison, we scheduled a company sports day in conjunction with our quarterly company party. Again, the sergeants and junior officers were tasked to take charge of certain events. Every event we could think of was given serious consideration. Besides the standard basketball, volleyball, and bench press, we included horseshoes, table tennis, pool, tennis, racquetball, and several others—anything to ensure maximum participation and effort. Again, the simple recognition, in the company formation, as the top platoon of the quarter was reward enough.

As a result of the massive monsoon rains in July, we were forced to remodel the day room after it was submerged in mud. We decided to recognize the many artists in the company by holding a contest to recognize the platoon that could paint the best mural on the new walls.

A quick review of the way each event supported the company focus of weaponry, battle drills, leader training, and physical toughness justifies the effort and training time expended. Every event required an action officer and NCO to develop a complete memorandum of instruction (MOI) five weeks before the event. Before the MOI was

TRAINING NOTES

approved and signed by the commander, the action officer had to conduct all the required coordination, develop a time schedule, and undergo a briefing and critique of his draft with the commander. Once it was approved, the action officer had to gather the resources, conduct a rehearsal with all supporting instructors and demonstrators, and then execute the event. All of this was significant leader training. The M60 competition included evaluating the weapons squad in occupying a support-by-fire position and executing crew drills during the live fire scenario. Both the M60 and rifle squad events included strenuous physical events and weaponry event in understanding zeroing procedures, fundamentals of firing, and live fire marksmanship. Obviously, the list

of events related directly to the company focus.

This kind of competitiveness would be disruptive if it ever were allowed to create dissention or animosity among the platoons. But this should not be a concern as long as everything is kept in perspective and the rewards do not outshine the events. Of course, the company must be a close-knit organization before embarking on this many events, and this closeness is often the contribution of the previous commander. As a result, Company A is a cohesive, ready force that has been built on healthy competition over the past year and a half.

A company commander controls many variables and intangibles that can make his company one of the best in the

Army today, but he should start out slowly and build up to it. He will be pleased with the results from one quarter to the next and will be a true believer when he leaves command and has a former member of the company visit to tell him how great it really was. This will confirm the emphasis on "cohesion through competition" and your personal feelings about the company you once commanded.

Captain Thomas H. Greer commanded Company A, 1st Battalion, 506th Infantry, in Korea and is now S-3 Air of the 75th Ranger Regiment. He previously served in the 1st and 3d Ranger Battalions, the 3d U.S. Infantry, the 4th Ranger Training Battalion, and the 82d Airborne Division. He is a 1991 ROTC graduate of Columbus (Georgia) State University.

Training Opportunities For Airborne Battalion Medical Platoons

MAJOR SCOTT T. GLASS

The three C-130s are on final approach to the drop zone, following the heavy-drop platforms by ten minutes. The troop doors are open, and paratroopers are standing by awaiting the jumpmaster's final command of "GO." In a couple of seconds, the sky fills with parachutes. Paratroopers land, recover their equipment, and rapidly move to their assembly areas. One soldier twists his ankle and word is relayed to the battalion medical platoon element to dispatch the drop zone coverage ambulance to check him out. Fortunately, it is nothing more than a mild sprain. In a few minutes the medical team NCO reports no more injuries. The ground troops quickly move out from the drop zone on their tactical training mission. The ambulance and the medical team return to the motor pool, park their vehicle, and are released.

Sound familiar? If this happens often—or even occasionally—in an airborne unit with organic medics, medical training opportunities are being wasted. Airborne medics need to be thoroughly tested in the tasks of getting equipment and supplies ready to drop, recovering this equipment efficiently, putting it into operation, and treating a wide range of casualty situations on the drop zone.

I commanded an airborne forward support company (FSC) in Italy that had an internal medical platoon supporting an infantry brigade in country. We tried various ways of increasing training opportunities for the platoon and learned many lessons that will be useful to others.

Individual Equipment

Medics who jump with aid bags and limited Class VIII supplies in their indi-

vidual rucksacks render first aid and perform lifesaving measures to seriously injured patients. The weight and size of the medical gear medics must carry, in addition to their own individual equipment, limit the number and the scope of injuries they can treat. But even with these limitations, it is still possible to conduct meaningful medical training.

The supported unit should designate soldiers to jump with moulage kits (to simulate wounds) and apply them immediately on landing on the DZ. The medics land, find the casualties, begin treatment, and evacuate patients.

Door Bundles

The weight and size of the medical gear that can be inserted by door bundles dramatically increase the capabilities for medical DZ training. A mass

casualty (MASCAL) situation, for example, is extremely difficult to address with only the medical gear jumped in individual aid bags and rucksacks. With the additional equipment and supplies, a MASCAL is within a unit's training capability. Our FSC procured a small generator that was dropped with the door bundle to power selected medical equipment.

Other training opportunities with door bundles are to rig and drop blood products, establish a limited Class VIII supply point, set up the advance treatment point for the brigade aid station (BAS), conduct MASCAL, and operate powered equipment.

Vehicles

Since four-litter M997 armored ambulances exceed the height restrictions for dropping from C-130 aircraft, their flexibility in deployment is limited. M996 HMMWV two-litter armored ambulances are considered fragile when airdropped. Cracks in welds and siding and dents can result in long, costly repairs. For these reasons, a unit may choose not to include the ambulances in the airdrop plans. This can adversely affect training opportunities for a medical platoon that is not equipped with M1035 softshell ambulances.

Our FSC was equipped with four-litter ambulances. The medical platoon in the company fitted a two-litter ambulance kit composed of 42 pieces (found in TM 9-2320-280-24P-1) to a platoon M998 HMMWV. This vehicle, which was airdropped twice during my tenure, gave the medical platoon a vehicle to evacuate patients to the BAS, transportation to reach training lanes immediately adjacent to the DZ, and a ready platform for vehicle secondary loads.

The training opportunities included vehicle rigging, planning secondary loads, tactical derigging, and access to training off the DZ.

Vehicle Secondary Loads

Vehicle secondary loads can take two forms—a load planned on an organic medical vehicle and a medical-specific package planned on a vehicle that is not organic to the medical platoon.

The FSC habitually uses an M998 HMMWV fitted with a two-litter kit. The standard load plan for this vehicle—configured for supporting a BAS—typically includes one or two modular tents, four to six Class VIII medical chests, and specialized x-ray and laboratory equipment.

Medical planners should request heavy-drop platforms to insert vehicles capable of supporting the medical plan and enhancing medical training. For airborne combat battalions that use M998s for an advanced trauma life support vehicle, the training potential increases if the vehicle has a two-litter configuration. With the two-litter kit,

Airborne medics need to be thoroughly tested in the tasks of getting equipment and supplies ready to drop, recovering this equipment efficiently, putting it into operation, and treating a wide range of casualty situations on the drop zone.

the vehicle can easily carry four or five trauma chests and Class VIII supply containers for airdrop.

If the mission plan cannot support a heavy-dropped medical vehicle, space should be requested as secondary loads on the drop plan. The key to this method is using every bit of available space on airdropped vehicles.

The medics can train on medical load planning, vehicle rigging and derigging, and BAS set-up.

Mass Delivery Systems

Medical equipment delivered by the containerized delivery system (CDS) and mass supply platforms offers another dramatic increase in the size and scope of medical support training. CDS bundles can be programmed into the sustainment phase of forces on the DZ. One mass supply platform, if properly loaded, can deliver the equipment and Class VIII supplies necessary to set up and sustain a functional BAS, including small and medium generators to provide electrical power.

Training opportunities include BAS drills, MASCAL, tactical derigging, Class VIII supply point, specialized rigging for medical equipment (x-ray and laboratory), and events requiring multiple pieces of powered equipment.

Training for Low-Density MOSs

The FSC's medical platoon includes soldiers in the following specialties:

- 91S (Preventive Medicine Specialist).
- 91K (Medical Laboratory Specialist).
- 91P (Radiology Specialist, commonly referred to as x-ray technician).
- 91A (Medical Equipment Repairer).
- 71G (Patient Administration Specialist).

While most airborne combat battalion medical platoons are almost exclusively 91B (Medical NCO), every effort should be made to integrate and include the low-density MOS soldiers in productive DZ training.

Preventive Medicine. Tasks for the 91S soldiers includes conducting an entomological survey of the DZ or adjacent operations area and drawing and testing water samples. Insect and rodent traps can be inserted in door bundle loads or on vehicle secondary loads and then emplaced as part of a training task. Limited water sampling gear can be jumped in the 91S's individual rucksack. Heavier and more fragile testing gear requires a door bundle or a vehicle secondary load.

Laboratory. Laboratory tests can be programmed with fluids extracted from soldiers on the DZ, using a light microscope with 10-power, 30-power, and 100-power magnification, jumped in a well-padded rucksack. Blood can be drawn under controlled circumstances, as can urine samples. Dipstick urinalysis, white blood cell count, and blood glucose are included in this spectrum of training. Additional chemicals and test materials can be dropped by door bundle or in vehicle secondary loads. Our FSC laboratory specialist was working on executing malarial smears and microscopic urinalysis tests.

Radiology. Conducting x-rays on a DZ within minutes of a parachute drop is a challenging task, but one that, performed under certain conditions, can greatly help the attending surgeon with

TRAINING NOTES

treatment and evacuation decisions. The x-ray apparatus requires electrical power, and hence a generator. But once past these planning considerations, the x-rays can be done.

Administration. It is difficult to develop training for MOS 71G on the DZ. But if a MASCAL is planned after an airborne operation, useful training is available. The individual 71G can jump limited forms in his rucksack with more in the door bundles, and a field desk can be loaded onto a mass supply platform.

Medical Maintenance. Training for the medical equipment repairer after a parachute drop is the most challenging to develop. Equipment damaged in the drop, if any, could be assessed and an expedient repair performed. One solution might be to have the medical equipment repairer perform organizational services on a piece of equipment inserted on the DZ. Another solution is to have him assist in the calibration of specialized medical equipment such as x-ray apparatus.

Lessons Learned

The following are some of the lessons we learned from this training:

Plan and execute specific training for all medical MOSs available to the training medical unit. Having the soldiers in low-density MOSs jump and "lend a hand" in the derigging and set-up of an activity is proper and appropriate in most cases, but this should not become the primary focus of their training.

Protect fragile medical items from damage. Items damaged by impact are of little use to an injured soldier, and extreme care must be taken in configuring them for aerial delivery. Hard plastic cases with foam and bubble-wrap cushioning work best for loads jumped in individual rucksacks. For door bundle insertion, FSC medics use a braced plywood box that fits inside an A-21 cargo bag to supplement protection of the contents. The outer shell of the box provides extra protection on impact and prevents most load shifts during descent.

Integrate training with casualties from the supported unit. A comprehensive medical plan allows for treat-

ment by combat lifesaver personnel before evacuation through small-unit channels to the supporting aid station. This offers training for patient records specialists and exercises evacuation channels and casualty tracking. Every echelon of medical treatment benefits from this integration.

Use moulage kits to add realism. Casualties can be designated beforehand to jump with the moulage kits issued to them in their individual gear. An exercise observer-controller can issue a kit to an assessed casualty. MILES casualty cards are helpful for initial diagnosis, but a detailed casualty card is needed to instruct the casualty on how to act to provide the greatest training for the attending 91B.

Involve medical leaders in planning and sequencing. Medical leaders benefit from being involved in the planning and sequencing of loads carrying medical supplies and equipment. Particularly helpful are wargaming events that cause bundles or heavy loads to abort. Medical items should be cross-leveled to keep aborted loads from compromising effective medical support and training.

Rehearse assembly plans and contingencies for vehicle secondary loads not dropped on organic medical vehicles. Medics parachuting on the mission must know which vehicles they will help derig and take charge of medical equipment onboard. In addition, the vehicle crews must thoroughly understand what to do with the medical equipment loaded on their vehicles if airborne medics do not arrive on the DZ to take charge of it. A drop off point should be designated, understood, and rehearsed.

Develop skills in preparing refrigerated supplies. Procuring and configuring blood products for aerial delivery is a special challenge. It is extremely difficult to secure blood items for a peacetime airdrop because they present a medical hazard if opened or ruptured on impact. To sidestep these problems, our FSC medics used standard IV bags with the contents tinted by food coloring to simulate blood.

Keeping the contents within the required temperature range for blood is

vital (approximately 1-6 degrees C or 33-43 degrees F). Our FSC medics attempted to drop blood products, but aircraft movement regulations prevented the use of dry ice. The medics countered by using regular ice inside an insulated container in a door bundle. Water was pre-frozen inside plastic drinking bottles before being placed in the blood container.

Door bundles rigged immediately before aircraft take-off seem to be the best method of inserting readily available blood or blood products. Dispersion on the DZ is limited and the blood products can be maintained within the proper temperature range, but this would be a challenge with a vehicle rigged for airdrop and standing by for several hours.

Consider power generation as part of load planning. Generators in the 5-kilowatt range are too large to rig in door bundles, and they take up a lot of space in mass supply loads. Our FSC locally purchased a small generator to fit inside the outer door bundle box to provide power for the X-ray equipment.

Plan and rehearse ground assembly. During an operation where wounded soldiers are likely, medical personnel should jump, land, and move directly to their assigned door bundles or vehicles to begin derigging. Of course, primary and alternate load assignments should be rehearsed.

Consider ground tactical plans. If the medical equipment will be inserted into the operational area by door bundle or mass supply methods, the distance it will have to be moved to the designated aid station should be carefully considered. A great distance will lengthen the time required for assembly and set-up. The same is true for loads dropped with vehicles. In case the vehicle is damaged on impact, an alternate site for the aid station should be selected, rehearsed, and briefed.

Familiarize 91B personnel with vehicle rigging. Regardless of whether M998s, M996s, or M1035s are to be airdropped, 91B personnel should be familiar with the rigging procedures for them. Rigging these vehicles for airdrop twice a year is probably the minimum necessary to teach and sustain this

important skill. Even if the drop plan does not support heavy-dropped ambulances, the vehicle can still be rigged and notionally placed on the DZ.

Airborne combat units that take their airborne medical personnel through a graduated series of training events with gear jumped on the soldier, inserted in door bundles, or dropped with vehicle

secondary loads will have better trained, more highly motivated, and more confident soldiers to treat casualties. This competent, energetic, and confident care can be attained only through challenging medical training. This process is not easy, but it will save lives on the next peacetime or combat parachute assault.

Major Scott T. Glass commanded the forward support company in the Lion Brigade, as well as the Headquarters Support Company, 528th Special Operations Support Battalion, which also had an airborne medical platoon. He is a 1984 ROTC graduate of the University of Georgia and holds a master's degree from Webster University. He has written several articles for publication in *Infantry*.

Marksmanship Training

More Than the Basics

SERGEANT FIRST CLASS STEVEN D. MILLER

Most U.S. Army infantry battalions consider marksmanship training one of their most critical tasks. A unit can trace its successes (or failures) to the level of marksmanship proficiency it displays. But the actual marksmanship training that takes place within a battalion normally consists of basic zeroing and qualification requirements with sporadic visits to a live fire range. If our soldiers are to become proficient in the task that will ensure their success—and indeed survival—on the battlefield, marksmanship training must consist of more than the basics.

Over a period of 12 months, 3d Battalion, 187th Infantry, at Fort Campbell, Kentucky, developed and implemented a marksmanship training program that succeeded in getting soldiers better trained on their assigned weapons. Additionally, this program provided the battalion level leaders with vital information pertaining to the proficiency of the battalion firers and brought the unit to the next level in its warfighting capabilities.

Implementing this system required a series of planned events: The first was a meeting the battalion leaders held with all battalion NCOs and officers to establish a feasible marksmanship program that met the Standards in Training

(STRAC) requirement, while at the same time adhering to the constraints usually placed on maneuver units. The battalion commander was the primary facilitator of this meeting.

This meeting focused on how to improve marksmanship within the battalion. The discussion points included the following:

- What the unit is doing well with marksmanship.
- What changes are needed.
- How members of this group can effect needed changes.
- What do others need to do to effect needed changes.

Once the battalion had gathered input on the strengths and weaknesses in marksmanship from the company commanders, platoon leaders, and platoon sergeants, a master gunner was selected. The term *master gunner*, as used in a light infantry battalion, is considerably different from the way it is used in a mechanized infantry battalion. The light infantry battalion master gunner is first and foremost a link between the battalion and the subject matter experts, not only at home-station, but with other military organizations as well.

The battalion master gunner provides the battalion with the latest information on new weapon systems, gathers and

disseminates marksmanship training strategies developed by other units, and maintains a filing system on all marksmanship conducted within the battalion. These files are readily available to all leaders, especially new platoon leaders who may need guidance on specific requirements, such as how a range firing was previously conducted within the battalion.

The main objective for the master gunner is to reinforce the commander's guidance on marksmanship. This is accomplished in various ways. First, the battalion S-3 developed approximately 20 different posters depicting the battalion's weapons systems, which included the characteristics and capabilities of all MTOE assigned weapons. With help from the local print plant these were enlarged and acetated. Most of the printouts were selected from the technical manual (TM) or field manual (FM) pertaining to a particular weapon. These posters were then distributed throughout the respective companies. For example, some of the posters for the three line companies included the M16A2, M240, M249, M203, and AT4. The antiarmor company received posters of the M4 Carbine, TOW, Mk 19, and the M2 .50 caliber machinegun. The headquarters and headquarters

TRAINING NOTES

company (HHC) received posters of the M2 .50 caliber, the 81mm mortar, the 9mm pistol, as well as the other small arms weapons within the company.

The posters were placed in areas of high visibility for the soldiers to read. This proved to be a tremendous tool for helping soldiers learn the characteristics and capabilities of their individual weapons.

Next, the battalion scheduled officer professional development (OPD) sessions on marksmanship training. Guest speakers from the post's range control were invited to attend and offer their expertise. This greatly improved the working relationship between the battalion and range control personnel. The vast experience of the range control staff provided leaders with a great deal of insight and ideas on how to get the most realistic training from the maneuver ranges as well as the known distance (KD) range. Most Army posts in the continental United States, and even overseas, have range experts who are often retired military officers and NCOs, and units should seek their help. Since these people control a very important asset that all units want—the ranges—it is also important to build good rapport.

Marksmanship Gates

The battalion developed a series of "gates" for each soldier in terms of marksmanship (Figure 1). To progress, each soldier had to go through the gates in sequence.

Before going to any range, preliminary marksmanship instruction (PMI) must be conducted. This is the most critical stage of marksmanship training. Commanders should include PMI on company training schedules to ensure that squad leaders have the time to train their soldiers before conducting live fires. Leaders should conduct training on a variety of tasks including:

- Operational characteristics of assigned weapons.
- The actual functioning of the weapons.
- Malfunctions and corrections.
- Marksmanship fundamentals.
- Basic and advanced firing positions.

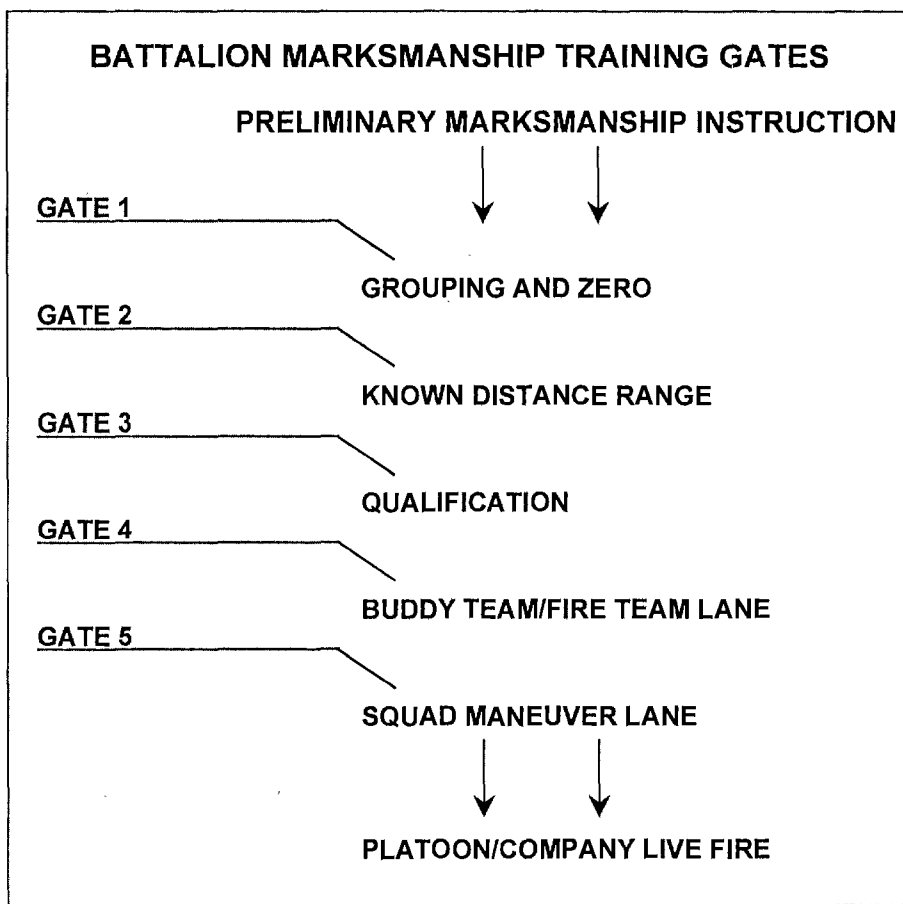

Figure 1

- Dry fire exercises.

The squad leader's role during each marksmanship phase is most important. During PMI, for instance, he must ensure that every soldier fully understands and can properly execute each of these tasks.

The first gate is shot-grouping and zeroing an assigned weapon. Each firer must have a coach throughout the firing process. (A checklist for the coach can be found in Field Manual 23-9, *M16A1 and M16A2 Rifle Marksmanship*. The purpose of shot-grouping is firing tight groups and consistently placing them in the same location on the target. If the soldier cannot consistently fire tight shot groups he is removed from the range and retrained. Once the soldier successfully fires a series of two tight shot groups, he then makes the necessary adjustments to his weapon and obtains his zero. During Gate 1, the squad leader should pay particular attention to both shooter and coach. It may be necessary for him to play the role of coach if a soldier is having more

difficulty obtaining tight shot groups.

Next, the soldier moves to the KD range to confirm his zero at actual distance. This is Gate 2. Units should try to schedule zero ranges and KD ranges on the same day. While on the KD range, the squad leader teaches wind effects and bullet trajectory to each soldier and reiterates the importance of a proper zero. Immediate target feedback is the squad leader's most valuable training aid on the KD range.

Gate 3 is qualification on a soldier's assigned weapon. By this time, the soldier's confidence level with his weapon should be high, because he knows he can engage targets effectively out to 300 meters. If the previous gates are executed to standard, there will be a definite increase in a unit's qualification scores. Although the squad leader's role at the qualification is limited, his presence is particularly important because it shows the firers that he is genuinely concerned about their shooting ability.

Gate 4, conducted on a maneuver

RANGE ASSESSMENT

DATE: _____

COMPANY: _____ RANGE: _____

OIC: _____

NCOIC: _____

OTHER LEADERS PRESENT _____

TASK: _____

CONDITION: _____

STANDARD: _____

TYPE OF PMI CONDUCTED: _____

TYPE OF CONCURRENT TRAINING: _____

TYPE OF REMEDIAL TRAINING: _____

HAVE ALL SOLDIERS FIRED ON KD RANGE PRIOR TO FIRING ON TODAY'S RANGE? _____
(ALL ZERO RANGES DISREGARD THIS QUESTION.)

IF NOT, WHO AND WHY? _____

NUMBER AND TYPE OF ROUNDS EXPENDED: _____

NUMBER OF SOLDIERS ZEROED/QUALIFIED AND COMPANY:

	ZEROED	EXPERT	SHARPSHOOTER	MARKSMAN
HHC				
A CO				
B CO				
C CO				
D CO				

RANGE ISSUES: _____

OBSERVATIONS: _____

RECOMMENDATIONS: _____

ADDITIONAL COMMENTS: _____

Figure 2

range, is the buddy team/fire team lane. At this gate the soldier begins to develop confidence in maneuvering with the soldier to his left and his right and how to properly execute individual movement techniques, as well as rapid magazine changes. While conducting the buddy team/fire team lane, the squad leader is overseeing the team leaders and ensuring that training is conducted to standard. At this gate, the squad leader's role is that of observer-

controller. Even at this level an informal after-action review should be conducted upon completion of each firing iteration.

Gate 5 is the squad maneuver lane, where the soldiers in the squad apply all of their previous marksmanship training. Target feedback is critical during squad live fire exercises because it tells the squad leader which soldiers are actually getting target hits and which ones are firing ineffectively downrange. It is

imperative that squad leaders show individual soldiers all of the targets after each engagement is complete. The training culminates in platoon and company live fires.

Providing Incentives

Another tool that can be used to emphasize the importance of marksmanship and instill a spirit of competition is to offer informal awards for marksmanship success. To meet this need, 3d Battalion established the Sergeant Alvin C. York Award. After each intensive training cycle, the battalion commander presented the award to a platoon from each rifle company, the best mortar crew, and the best scout squad. The award is nothing more than an E-type silhouette (complete with bullet holes) with the unit designation stenciled on it and a statement that it was the best during a particular training cycle. Although this may seem trivial, soldiers usually try very hard to earn it. Company commanders, executive officers, and first sergeants select the best platoon on the basis of all platoon qualifications and how well maneuver ranges were conducted.

Assessing the Program

To help give the battalion feedback on individual marksmanship qualifications, the master gunner developed a two-page range assessment sheet, the contents of which are shown in Figure 2.

These sheets provide data on the number of soldiers from each company to qualify with their assigned weapons, the level of qualification, the amount of ammunition required, as well as any problems associated with the planning and execution of the range. At the completion of all ranges, the officer in charge must turn in this information to the battalion. The master gunner, the battalion S-3, and the battalion commander review each range assessment sheet and write their comments. Then copies are distributed to each company. This not only provides the commander with feedback on his company, but also gives him an opportunity to see the statistics of the other companies in the battalion. In addition, the range as-

TRAINING NOTES

assessment sheet gives the battalion S-3 a systems check of the battalion's marksmanship program.

Marksmanship training is an ongoing process within a battalion, and if it is to be successful, it must be command driven. If the commander takes an active interest in a marksmanship training program, so will everyone else. Many

methods have been developed to improve marksmanship capabilities. Creativity and gaining support from the many self-starters found in each unit can pay big dividends in a unit's marksmanship abilities. In the end, if each and every soldier can claim—and believes—that if it can be seen it can be hit, then the program is a success.

Sergeant First Class Steven D. Miller served as operations NCO for the 3d Battalion, 187th Infantry, and an assistant operations NCO in the 2d Infantry Division in Korea, and is now a military instructor at Cameron University, Lawton, Oklahoma. He has also served as a scout team leader, a sniper, long-range surveillance detachment leader, and observer-controller at the Joint Readiness Training Center.

Mechanized Platoon TTPs In Peace Enforcement Operations

LIEUTENANT KEVIN J. PERERA

Peacekeeping operations require a modification of the usual mission tasks and the "Warrior" mindset. Such an environment requires an overt presence, but soldiers must be prepared to resort to warfighting skills the moment a situation deteriorates. It is as if they were operating under a delicate On/Off switch. At any moment—because of the reaction of a single soldier to a threat, real or perceived—a peaceful situation can turn into a police action and then deteriorate into a combat action.

In Bosnia-Herzegovina, for example, the rules of engagement (ROEs) are extremely liberal and reaffirm the ability of an individual soldier to use lethal force in the event a threat materializes. In all situations, the goal is to defuse situations that may escalate the event, while showing a determined and resolute presence. All soldiers must communicate and act as a team in a dynamic environment. This is accomplished by platoon-level wargaming of possible contingencies, and the reiteration of battle drills before every mission. As a Bradley platoon leader assigned to a company team, I found that peace enforcement called for new tactics, techniques, and procedures (TTPs).

We executed all peace enforcement

operations with the capacity to support and transition into combat operations. All weapons systems, including all small arms, were fully up-loaded with a complete complement of ammunition. M203 gunners had a full basic load of lethal and non-lethal ammunition, and the vehicles always carried riot control gear (face shields, body shields, shin guards, and batons).

The unit was augmented with several items of equipment from Combat

Equipment Group Europe to support operations. The line platoons were augmented with four armored XM1109 model high-mobility multipurpose wheeled vehicles (HMMWVs), two M2

PATROL LEADER PCI CHECKLIST

1. Receive FRAGO from Commander.
2. Patrol Leaders picks up mission dispatch from TOC.
3. Review daily intel update.
4. ANCD and GPS functional with current fills and SOI.
5. NVGs with extra batteries.
6. Radios functional with current fill and frequencies.
7. Vehicles dispatched through current mission and all dispatches signed and present.
8. Crew served weapons mounted/checked.
9. Combat lifesaver bags.
10. Pyrotechnics.
11. Antiarmor missiles (AT4).
12. Tow straps/Tow bar and spare tire.
13. MREs and water per vehicle.
14. SFOR ID cards and ID Tags.
15. Windows/lights/reflectors cleaned.
16. Radio check complete (internal, external and higher).
17. Load plan (no loose equipment).

PATROL LEADER MISSION/SAFETY BRIEF

1. Risk assessment (Task, Purpose, Conditions. Discuss risks and management techniques).
2. Immediate Action Drills: React to Sniper, Mine Strike, Indirect Fire, Ambush, Drive-by shooting (mounted/dismounted; moving/halted).
3. 9-line MEDEVAC (format is posted on all radios).
4. Patrol routes and Checkpoints.
5. Link-up plan if patrol is separated.
6. Order of movement and distance between vehicles (25-50 meters).
7. Patrol speed (10 mph in AOR, not to exceed 35 mph).
8. Weather conditions and route status.
9. Vehicle break down procedures.
10. Intelligence update.
11. Force protection level and weapons status.
12. Always assume shoulders of the road are mined, especially on infrequently traveled routes.
13. Do not leave the route unless it is absolutely imperative.
14. Assume mines are everywhere (potholes, dirt piles).
15. Drive defensively at all times.
16. Do not chamber a round unless it is absolutely necessary.
17. You always have the right to defend yourself.

PRE COMBAT INSPECTIONS—THE STANDARD FOR ALL OPERATIONS

1. **RUCKSACK:** Ensure the frame is serviceable; check straps, buckles and snaps. All outside items are secured.

2. **RUCKSACK CONTENTS:**

- 2-T-shirts
- 2-pairs of socks (black)
- 1-Goretex Jacket
- 1-Goretex Pants
- tool
- 1-Poncho
- 1-set Poly-Pro (top & bottom)
- 1-Pair BDUs
- 1-Pair white work gloves
- 2-Sets underwear
- 1-Set Wet WX Gear (w/rubber boots)
- 1-Pair of boots

3. **SOLDIERS ITEMS:**

Uniform Appearance: FULL BATTLE

RATTLE

- 1-ROE card
- 1-Set ID tags w/medical tag
- 1-US Government ID Card
- 1-SFOR ID card
- line MEDEVAC card
- 1-Pen and notebook
- 1-Green Chemlite
- 4-Zip ties

4. **LEADERS ITEMS:** On Bradley or HMMWV

- 1-Current map w/CPs, patrol routes, & ZOS, and current overlay
- 1-Lensatic Compass
- 1-Sensitive Items list
- 1-Radio Freq cheat sheet
- 1-Pyro Ammo Can
- 1-PLGR w/fill & spare batteries
- 1-Bosnia Country handbook
- 9-line UXO report
- 1-Risk assessment worksheet
- 1-ANCD per section

5. **LBE/LBV:** all straps and attached equipment tied down/secure.

- 6-magazines in ammo pouches (rounds face down)
- Quart canteens with covers and FULL
- 1-First aid pouch, left side, facing up w/:

- 1-field dressing
- 1-casualty feeder report
- 1-Witness statement card
- 1-Bayonet
- 1-Flashlight
- Pro-Mask (in easy reach or worn)

6. **SPECIAL EQUIPMENT**

- 2-AN/PVS7Bs per vehicle
- 1-set PAQ per LDR (mission dictates)
- 1-Set bolt cutters
- 1-Camera (mission dictates)
- 1-Mine Marking kit

7. **MOUNTED PATROL EQUIPMENT:**
Valid dispatch and log book on hand complete with accident reports and drivers signature.

- Before PMCS complete and recorded
- Vehicle topped off
- Valid Drivers license
- 2-six packs of water per vehicle
- 2-cases MREs per vehicle
- Gallon diesel per vehicle
- 2-Rolls of concertina wire
- Crew served weapon, mounted, ammunition present and checked by an NCO (headspace and timing)
- 8-Pickets per vehicle (Brad Only)
- 1-Picket Pounder per section
- 5 Gallon can 15w/40 per section
- 5 1 Gallon jugs of Anti-Freeze
- 4 1qt cans of Hydraulic fluid per section (Brad)
- 4 1qt cans of DEXTRON III per section (HMMWV)
- 1 5 gallon GAA per section (or 1 gallon can per vehicle)
- 1 ½ gallon CLP per section
- 2 qt. GMD per section (Brad)
- ALL EQUIPMENT TIED DOWN**

8. **AMMUNITION:**

- M16: 7 Magazines 5.56mm
- Ball/Tracer mix = 210 rds
- M249: 4 Boxes 5.56mm linked = 800 rds
- M203: Mission dictates
- M2 50 cal: 500 rds per guns
- Mk19: 96 rds HE
- M60: 800 rds

1 Pyrotecnics can per vehicle

- 1 HC Smoke
- 1 red smoke
- 1 CS smoke
- 1 white para flare
- 1 red star cluster
- 1 AT4 per vehicle
- M2A2: Basic load

9. **COMBAT LIFESAVER BAG:**

- 1 per vehicle
- Inspection sheet and shortage annex present

10. **SECTION LEADER PATROL BRIEF**

- Situation
- Weather
- Terrain
- Friendly patrols in area
- Safety considerations
- Mission
- Concept of Operation
- Route
- CPs
- SPs
- RPs
- Contingencies (what ifs?)
 - Actions on contact
 - Lost
 - Injury
 - Medevac
 - Indirect Fire
 - Sniper
 - Ambush
 - Mine Strike
 - Hostile or agitated civilians
 - Break Contact
 - Movement formations
 - Road march/catch up speed
 - Vehicle distance
 - Recovery operations
 - Accident procedures

11. **COMMUNICATIONS PROCEDURES**

- Current fill in ALL channels
- MEDEVAC in #6
- 9 Line format on radio
- Commo checks: internal/external
- Commo check with Company
- Additional batteries for all equipment

heavy-barrel .50 caliber machineguns, one Mk 19 automatic grenade launcher, and one M60 machinegun. With this additional equipment, we could operate in a wheeled or tracked mode. The XM1109 has seating for four and a roof turret ring for a gunner. Bradley crews occupied the same crew positions on the XM1109. In addition the company was assigned several local national interpreters, who were hired by a defense contractor. Every time a platoon conducted a mission, they had an interpreter present to assist in interactions with the local people.

Depending on the mission and the

commander's intent, the unit could dispatch a 20-man element in four armored HMMWVs, or with the entire platoon mounted in Bradleys. The goal was to rotate between the two for proficiency, presence, and equipment maintenance. Whenever an element left the base camp, the soldiers were in full combat gear, at the appropriate weapons level status, and prepared to conduct extended operations as the situation dictated.

All leaders received a daily intelligence briefing, and changes to the commanders intent and priority intelligence requirements (PIRs). This infor-

mation was disseminated to the lowest level in the area of responsibility (AOR) to ensure that all soldiers were aware of the situation.

The unit conducted weekly rotations of mission requirements of its three assigned tasks—AOR patrols, quick reaction force (QRF), and force protection (guard duty). The task force commander assigned each company a specific named area of interest (NAI) to provide for continuity within the unit and with the local populace. Our unit operated in one of the resettlement areas that occupy the Zone of Separation. Since this area was heavily destroyed

BRADLEY PREPARE AND SECURE WEAPONS SYSTEMS

1. PREPARE GUNNER'S STATION

Down load ammunition from feeder/Ensure the Feed chute is clear or ammo will load
 Clean Optics
 Check sight covers
 Check feed chutes and eject chutes
 Make sure bolt is in SEAR position
 Check HE and AP ammunition
 Misaligned rounds
 Clean
 Properly loaded in ammo ready boxes
 Turn on Thermal Sight
 Select AP, HE, TOW and then 7.62
 Go to manual and electrical FIRE
 Check trigger switches and cycle gun on Gunner's and BC's hand stations, and manual trigger on turret-traverse hand-wheel in each ammunition mode and firing rate
 Go to manual and electrical SAFE
 Release turret-travel lock, and clear turret
 Check traverse and elevation in high and low rates
 Adjust Diopter
 Select HE, turn RANGE control knob from 0 to 30
 Select AP, turn RANGE control knob from 30 clockwise back to 0

Select 7.62, turn RANGE control knob from 0 to 10
 Turn RANGE control knob back to 0
 Clear TOW and raise launcher
 Conduct TOW test
 Clear turret and check traverse and elevation in high and low rates
 Lower TOW
 Boresight 25mm gun, TOW and COAX
 Boresight night sight
 Index battlesight ammunition and range
 Up load ammunition IAW weapons status

GUNNER'S INITIALS: _____

BC'S INITIALS: _____

DATE: _____

2. SECURE GUNNERS STATION

Traverse turret to 6,400 mils
 Set gun to -10
 Close Ballistic Shield doors
 Set radios to STANDBY, then power off amp
 Close Gunner's Hatch
 Close BC's hatch
 Secure CVCs

during the war, activities in sector included monitoring freedom of movement, supervising humanitarian aid distribution and clearing wreckage, monitoring civilian activities, supporting elections, gathering human intelligence for the NAI database, and acting as a conduit between the local populace, the police force, the Joint Military Commission, and the security force. During AOR patrols, platoons maintained a day and night presence in the assigned AOR. This included either mounted or dismounted patrols or a combination of the two. During QRF, the platoon was prepared to react to any contingency in sector with a required roll-out time of 15 minutes. The platoon maintained its four Bradley fighting vehicles on a QRF ready-line with all personal equipment pre-positioned on the vehicles. Current radio frequencies were uploaded daily and the weapons systems given a pre-fire check. All Bradleys had a checklist that was attached on the gun shield in the turret. The system was checked by the gunner and the checklist was initialed and dated. The Bradley commander verified these checks and initialed the checklist. This way there was never a question about when the last

dry-cycle firing was conducted or how recent the boresight was. In the event of a call-out, unit members needed only rush to the vehicles, don equipment, conduct final precombat checks and inspections (PCIs) and communications checks and stage the vehicles while the platoon leader reported to the tactical operations center for a briefing on the current situation and the task and purpose. During a force protection rotation, the platoon was responsible for a portion of the perimeter security, defensive position maintenance, and main supply route reconnaissance patrols. AOR patrols and force protection required all members of the platoon and allowed little time for training. During its week as QRF, the platoon could train on collective and common tasks and whatever opportunity training tasks the commander had designated for that week.

Every leader created a "smart book" that contained all the vital information for operations in sector—ROE card, medical ROE card, fire support targets and procedures for release of indirect fires, uniform and weapons level matrix, identification sheet of "Persons Indicted for War Crimes," task force

checkpoints and casualty collection points, route names and status, mine-field overlays, PCI checklist, risk assessment matrix, translation sheet with common phrases in Serbo-Croatian, the Joint Military Commission handbook (a reference of all allowed and illegal activities and the actions to be taken if they are encountered in sector), and a friendly forces overlay. This information was vital when a key leader was unavailable (dismounted) and also provided a ready reference for all platoon members.

When conducting AOR patrols, I would give an operations order for the week of patrolling and daily fragmentary orders based upon the commander's intent and PIRs. A patrol matrix and overlay was submitted to the company TOC the evening before execution. With this information, the executive officer could create the company mission tracker for the task force TOC, and the commander could review the platoon leader's mission intent. Soldiers arrived at the vehicles one hour before start time, and key leaders completed individual and vehicle PCIs. The platoon leader reported to the task force TOC for a final out-brief. The platoon leader was required to coordinate with the S-2, engineers, fire support cell, and the battle captain before gaining approval to depart the base camp. The platoon leader then linked up with the platoon at the vehicles, confirmed PCIs, and gave his patrol brief. In order to combat complacency and prevent creating a pattern, I changed the composition and execution of the mission daily. I always had a mounted and a dismounted section when conducting operations. They not only mutually supported each other but also allowed us to flood our AOR with a determined presence. Our AOR was close enough to the base camp that I had the option of having the dismounts depart from one gate and the mounted section from another. The platoon leader and the interpreter usually traveled with the dismount section, while the platoon sergeant commanded the mounted section.

While conducting patrols, the platoon was task organized into three separate elements—the mounted section, the

dismounted section, and a static observation point (OP). The positioning of the OP was based upon recent activity in sector. They were usually placed in a two- or three-story building that had been cleared for reconstruction. From this vantage point, they monitored all vehicle or pedestrian traffic in sector and reported any suspicious activity to the mounted or dismounted section, which were both capable of rapidly reacting to the variable. The OP consisted of two to three soldiers armed with an M203 and an M249. They were augmented with the following equipment: binoculars, night vision goggles (AN/PVS7B, and AN/PVS4), Dragon thermal night site (AN/TAS5), AN/PAQ4, AN/PRC119, Combat Life-saver bag, a three-cell flashlight, and appropriate cold-weather gear and sleeping pad based on the weather. The sleeping pad enabled the OP to maintain a prone position on the concrete floor of the building without losing valuable body heat.

The dismounted patrol stayed on

cleared roads and paths used by the local nationals and often had chance meetings with them during daytime patrols. This was a vital part of the mission; the human intelligence gathered from these conversations and the rapport that was built was critical to mission accomplishment. During limited visibility, the patrol acted in a more covert manner, patrolling along the roads and paths, though maximizing the use of night vision goggles and the AN/PAQ4A/B. The AN/PAQ4 could be used to illuminate a room in a destroyed building; by targeting the room, the IR laser provided a back-light that would cast shadows upon personnel or objects in the room. Upon contact with locals or a suspicious situation, the patrol could go to white light. All members of the patrol were equipped with three-cell flashlights, which could provide either an even beam or a wide dispersion of light.

The mounted section continued movement in sector and was available to respond to any contingency encoun-

tered by the dismounted section or the OP. With either four M2A2 Bradley fighting vehicles or four XM1109 armored HMMWVs with weapons stations, the mounted section was a formidable force. The mounted section was also tasked with observation points along routes in sector to monitor vehicle traffic and project a presence.

These are several of the TTPs that are essential to mission accomplishment and force protection. The most critical fact to remember is that even a peace enforcement operation can deteriorate rapidly, and only training and wargaming contingencies will prepare your soldiers to react in an appropriate and graduated response.

Lieutenant Kevin J. Perera led a Bradley platoon in Company B, 1st Battalion, 36th Infantry, 1st Armored Division. Previous assignments included assistant operations officer and executive officer of V Corps long-range surveillance company.

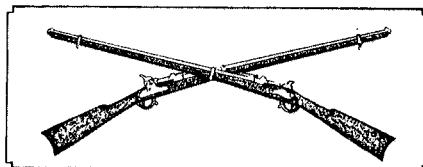

SWAP SHOP



Stabilizing the Long Whip Antenna for the PRC-119

The long whip antenna for the PRC-119 has always had one problem with its design—the base is prone to breaking. This is both disabling when conducting a mission and expensive to fix (about \$235).

Two soldiers in my company came up with a cheap inexpensive fix for this problem:

Buy a length of one-inch PVC pipe at a hardware store. Unscrew the piece of the antenna that attaches to the radio by placing a quarter in the slot at the bottom of the antenna, and turn it using a Gerber Tool.

Next, cut a piece of the PVC pipe approximately one and five eights inches (plus or minus one sixteenth inch).

Slide this section of pipe over the bottom of the base until it firmly pushes against the top of the base. Then replace the bottom of the base and retighten the screw to hold it in place.

Try to rotate the bottom of the base. It should be a little tight until the PVC pipe is worn in. Over time, the PVC pipe will wear, so it may need to be replaced approximately every six to eight months.

(Contributed by Captain Joshua Reitz, Company B, 1st Battalion, 187th Infantry, Fort Campbell, Kentucky.)

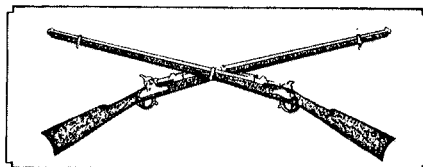

INFANTRY CAREER NOTES



NOTES FROM INFANTRY BRANCH, PERSCOM

Our mission at Infantry Branch, Total Army Personnel Command (PERSCOM) is to manage the assignments and professional development of Infantry officers in order to provide the best-trained Infantry leaders at the right time and in the best place for our Army.

In addition, we believe it is critical that we educate all Infantry officers on emerging trends and changes in personnel policy, especially as we implement Officer Personnel Management System (OPMS) XXI.

Thanks to advanced technology, there are now several ways Infantrymen can stay informed and involved in managing their future assignments and careers. Many Infantry officers have already discovered the

Infantry home page. We have published the site in a new format and continuously update it with new information. Because your assignment officer spends a great deal of time keeping the information current, many of your questions can be answered by a visit to this website: <http://www.perscom.army.mil/Opinf/innews.htm>.

For senior Infantry leaders, we also communicate through a "commander's shotgun," delivered by e-mail approximately every other month. These e-mails summarize upcoming and current events, along with any changes to or trends in assignment policies. They focus on issues that affect infantrymen in the rank of lieutenant through lieutenant colonel and provide tips and reminders to senior leaders about events or issues that will affect their subordinates.

They are intended to supplement what is on the home page, and many commanders also share them with their subordinates. All colonels and lieutenant colonels on Command Select Lists are on the distribution list to receive these e-mail summaries, and other senior Infantrymen can be added as well. Just call or e-mail your request to us.

Finally, we are equipped to communicate through e-mail, telephone, regular mail, and even personal interviews should you have time when in the Washington, D.C., area. If you plan to drop by PERSCOM, please call and make an appointment at least a day in advance so that we can increase the value of your visit by having a current copy of your officer record brief and microfiche record on hand. If you want to get a DA photo made during the visit, we sit across the hallway from a photo studio and can coordinate an appointment for you.

Upcoming DA promotion and school boards are shown here. (The Career Field Designation board will convene immediately following the Majors promotion board in April 2001.)

To help yourself or others get ready for a board, take a look at the board preparation portion of our home page, and then follow these tips:

Microfiche: Order early, ensure accuracy and completeness (all OER/AERs, award certificates, badge orders, and school diplomas). You can order your microfiche online from the home page.

DA Photo: Update within a year of the board or upon PCS or promotion (3/4 length, color, digital).

ORB: Go to your Personnel Services Branch and ensure accuracy and completeness (special attention to correcting current and past duty titles and the dates of your most recent physical examination and photo).

It is a good idea to update your microfiche and ORB during your birth month each year. This means you will have less to do in preparing for a board.

One Infantry!

Lieutenant Colonel Brian Baldy
Chief
Infantry Branch

UPCOMING DA PROMOTION AND SCHOOL BOARDS

DATES	YEAR GROUP	EVENT
01-23 Aug 2000	AZ-YG78; PZ-YG79; BZ-80	Colonels Board
22 Aug - 22 Sep 22	1st look - YG90; 2d look YG89	CGSC Board
October 2000	YGs 81-84	LTC Command Board
October 2000		ROTC PMS Board
November 2000	AZ-YG97; PZ-YG96	Captains Board
December 2000		SMU Board
January 2001		Colonel Command Board
March 2001	AZ-YG84; PZ-YG85; BZ-YG86	Lieutenant Colonels Board
April 2001		Senior Service College Board
April 2001	AZ-YG90; PZ-YG91; BZ-YG92	Majors Board

INFANTRY BRANCH (PERSCOM) CONTACT ROSTER

POSITION	NAME	EXT	E-MAIL
Branch Chief	LTC Brian Baldy	0445	baldyb@hoffman.army.mil
COL Desk	MAJ Charlie Glenn	5632	glenncc@hoffman.army.mil
LTC Desk	LTC Lee Fetterman	5524	fettermp@hoffman.army.mil
	MAJ Wes Gillman	5521	gillmanw@hoffman.army.mil
	Mrs. Leo Munoz	0445	munozl@hoffman.army.mil
MAJ Desk	MAJ Tom Webb	4459	webbt@hoffman.army.mil
	MAJ Karl Reed	5522	reedk@hoffman.army.mil
	Mrs. Phyllis Harley	5511	harleyp0@hoffman.army.mil
BQ CPT Desk	CPT Paul Fellingner	5518	fellingnp@hoffman.army.mil
	CPT Tom Mackey	5520	mackeyt@hoffman.army.mil
	Mr. Tony Woods	6706	woodst@hoffman.army.mil
1LT(P)/NBQ CPT Desk	CPT Scott Halstead	4176	halsteas@hoffman.army.mil
	CPT Sean Bernabe	5596	bernabes@hoffman.army.mil
	Mrs. Debbie Beard	3250	beardd@hoffman.army.mil
2LT/1LT Desk	Mrs. Juanita Walker	5973	walkerj@hoffman.army.mil
Phone numbers: DSN: 221-XXXX; Com: (703) 325-XXXX; FAX: 5514/5463.			
Branch Address: Commander, PERSCOM, ATTN: TAPC-OPE-I, 200 Stovall St., Alexandria, VA 22332			

BOOK REVIEWS



Soissons, 1918. By Douglas V. Johnson II and Rolfe L. Hillman, Jr. Texas A&M Press, 1999. 213 Pages. Maps, Index, Bibliography. \$24.95. Reviewed by Colonel Christopher B. Timmers, U.S. Army, Retired.

From 18 to 22 July 1918, 12,000 soldiers and Marines were killed, wounded, or listed as missing in action in an offensive that essentially sealed the fate of the German army and, by extension, signaled the end of the First World War.

Detailed analyses can be found of almost any battle in any war in history. *Soissons, 1918* has all the detail that passionate historians could ask for, but it has something more going for it: Added to the scholarly prose of historian Douglas Johnson is the down-to-earth writing of the late Rolfe Hillman, Jr., who retired from active duty as an Army colonel in 1972. We read in the second chapter that only two-thirds of the 28th Infantry Regiment's strength would be attacking over the battle sector's worst terrain. Such was the planning of the inadequately informed and unseasoned regimental staff. But we also read that "Staff officers working in near vacuums are dangerous to the health of infantry soldiers." This line could not have been written, with all due respect, by Dr. Johnson. It could only have been written by Colonel Hillman, a man who had commanded men in battle. Happily, such observations are liberally sprinkled throughout this work, not with a sense of sarcasm but out of a devotion to the truth.

For those who generally do not care much for the study of World War I, this book is a very readable primer. The organization of Army regiments, brigades, and divisions is discussed in detail (and a side note, companies could contain up to 250 men). It was common for battalions to be commanded by majors or even captains; regiments, as some will remember, were led by colonels, and brigades (as the title suggests) by brigadier generals. Modern military historians may be surprised to learn that an infantry division in the field consisted of more than 28,000 men, commanded by a major general, and that he not only had to provide rations for this large number of troops but for more than 2,000 horses and mules as well.

Our Marine Corps friends will also find something to their liking. At Soissons, the 4th (Marine) Brigade (5th and 6th Marine Regiments) were attached to the Army's 2d Division, and they acquitted themselves in fine leatherneck fashion. And the AEF units in this action could be considered a truly international formation: The first Moroccan Division was attached to XX Corps with its compliment of Foreign Legionnaires, Tirailleurs, and Zouaves.

I have found only one defect in this book: The maps are either hard to read or drawn in such a fashion that they do not exactly match the description of the flow of battle. Still, with effort, they can be understood, and this flaw—when weighed against the larger virtues of detail, narrative, exhaustive references, and appendices—is rather piddling stuff. Even if you are not an aficionado of World War I, this book should find space on your shelf.

Semper Fi—Vietnam: From Da Nang to the DMZ, Marine Corps Campaigns, 1965-1975. By Edward F. Murphy. (Originally published in 1997.) Presidio Press, 2000. 356 Pages. \$19.95, Softbound. Reviewed by Dr. Joe P. Dunn, Converse College.

More than 500,000 Marines served during the six years of combat operations in Vietnam. At the war's high point in 1968, more than 25 percent of the U.S. Marine Corps was stationed in Vietnam. The 13,070 killed in action and 88,630 wounded constituted a casualty total greater than the Corps suffered during World War II. The Marines fought a variety of wars under a wide range of conditions, including well-known battles at Con Thien, Chu Lai, Hue, Khe Sanh, Operation Dewey Canyon in the Da Krong Valley, and Dong Ha, as well as the daily treks "humping the boonies" in the jungle. They also developed the quite successful Combined Action Platoons, which served as models for later pacification and Vietnamization.

Military historian Edward Murphy—author of a three-volume series on Medal of Honor recipients in three wars and the very fine history of the 1967 battle of Dak To in the Central Highlands—offers the first one-

volume popular history of the entire time the Marines were in Vietnam. The book's time span covers the landing of the 2d and 3d Battalions, 9th Marines, on 8 March 1965 at Da Nang through the ending of Marine combat operations in May 1971, the advisory role to the South Vietnamese Marine Corps after that, to the departure of the last eleven marines of the U.S. Embassy security guard detachment.

The book is a well-written, lively, informative narrative that pursues the theme that the Marines fought honorably and well in a war without a strategy for victory.

Popular military histories serve a valuable function as they make important events accessible to the general reader. Several popular histories of Marine activities in individual battles, campaigns, or periods—especially those by Eric Hammel, Keith William Nolan, and Robert Pisor—are available, but Murphy's contribution provides the comprehensive account previously missing. It matches similar popular accounts of the U.S. Army's role. This is a book that both experts and novice students will enjoy.

General Matthew B. Ridgway: From Progressivism to Reaganism, 1895-1993. By Jonathan M. Soffer. Praeger, 1998. 246 Pages. \$59.95. Reviewed by Colonel Cole C. Kingseed, U.S. Army.

Few American generals have compiled military records as distinguished as that of General Matthew Ridgway. Commander of the 82d Airborne Division and the XVIII Airborne Corps in World War II; Commander-in-Chief, Far East in Korea; and Supreme Commander at NATO, Ridgway established himself as a leader of remarkable talent, in both the martial and the political areas. This book, the first full-length biography of this exceptional soldier, reflects social scientist Jonathan M. Soffer's empirical findings that Ridgway represented an ideology that favored the build-up of a state-controlled military-industrial economy through deficit spending. Although such an approach may be satisfying to organizational theorists, it leaves the average reader trying to discover the real Ridgway and his rightful place in history.

BOOK REVIEWS

"Lee's Miserables," in imitation of Victor Hugo's *Les Miserables*.

Power's work is much more narrowly focused than Wiley's studies, since he examines only the fighting men in Lee's Army of Northern Virginia and only during the last part of the war, from May 1864 through the surrender at Appomattox in April 1865. His study of the Confederate fighting man, both officer and enlisted, in Virginia during those months provides a sense of immediacy and openness of experience seldom seen in Civil War histories. The author relied solely on the first-person accounts (primarily letters and diaries) that the soldiers wrote during those 11 months, not at some later time after the war, when most Civil War reminiscences were penned.

Power provides an excellent, well-written summary of the campaigns fought during this period. Interspersed with those strategic and tactical foundations are the thoughts, experiences, and expectations of the Confederate soldiers fighting under Robert E. Lee in the remaining months of the Confederacy's existence. Power allows the men to speak for themselves and conveys to the reader through their words what it was like to "be there" in the ranks on the battlefields of Spotsylvania and Cold Harbor and the trenches of Richmond and Petersburg, and when the flags were furled for the last time at Appomattox.

This history is recommended for anyone who wants to know more about the thoughts and actions of the fighting man of this era, particularly in an army that faced increasingly heavy odds against it in men and materiel. Hopefully, similar studies will be written in the years to come on other parts of the Civil War and how those soldiers compared to the soldiers of Lee's army.

***The Paratroopers of the French Foreign Legion: From Vietnam to Bosnia.* By Howard R. Simpson. Brassey's, 1997. 162 Pages, Photographs. \$25.00.** Reviewed by Michael F. Dilley.

In 1945, while he was in Marseilles, waiting to be transferred from the recently concluded war in Europe to the still raging war in the Pacific, Howard Simpson had his first contact with the *Legion Etrangere*—the French Foreign Legion. Over the next 50 years, he had many encounters with the Legionnaires, particularly with the men of the parachute battalions. In 1994, after finishing his book *Dien Bien Phu: The Epic Battle America Forgot*, he decided to write a history of just the parachute forces of the Legion. The result, *The Paratroopers of the*

French Foreign Legion: From Vietnam to Bosnia, is as much a personal homage to the unit and its men as it is a unit history. It is well worth your reading time.

As the Legion is organized today, it consists of several regiments of Infantry, Cavalry, and Combat Engineers, but there is only one regiment of paratroopers—the *2eme Regiment Etranger Parachutiste*—commonly referred to as the 2nd REP. In 1948 the Legion established the first of several parachute battalions (called BEPs, after the French acronym). These battalions were designed for use overseas, as was the Legion itself. There have been several organizational changes over the years, caused as much by politics as by military necessity; the 2nd REP is now the Legion's only remaining parachute unit.

The regiment is composed of five combat companies, a support company, and a special long-range reconnaissance detachment of 25 Legionnaires. Each company has a specialized area of expertise, from mountain operations to urban combat. There is no battalion element in the organizational breakdown; it goes from regiment to company. Today, the regimental headquarters is at Calvi, on the island of Corsica. Several of the combat companies are deployed to various places in the world.

In addition to his personal research and research in the French national and Legion archives, Simpson spent several weeks at Calvi learning about the regiment firsthand. The commander gave him free rein to go anywhere in the regiment and talk to anyone, and he was accepted by the paratroopers. Simpson interweaves the history of the regiment with his personal experiences in observing these soldiers in garrison and training. The result is a dramatic, easy-to-read but hard-to-put-down book. Mixed in along the way, Simpson explains the history and politics of the Foreign Legion, including several historical encounters with the enemies of France. The most detailed historical portion deals with the 2nd REP operation in 1978 in Zaire, rescuing American and European hostages of Cuban-led insurgents. He also discusses the traditions of both the Legion and the 2nd REP.

This is Howard Simpson's 14th book; he has written fiction and non-fiction, detective stories, and military histories. He is a former member of the U.S. Foreign Service, serving as U.S. Consul in Marseilles three times. He has been a war correspondent and a lecturer at advanced military and diplomatic schools. From all this, he brings a different but very interesting perspective to the history of a unit of elite warriors. I rec-

ommend this book, especially to students of 20th Century military history.

***The Bill Walton 3D-CD Project.* A CD-ROM produced by Dan Shelley. \$35, U.S. postage paid to anywhere in the world. Order by e-mail: dshelley@ddd.com.**

Anyone interested in stereo photography will find this CD-ROM interesting and fun.

Bill Walton, formerly a photographer for the Public Affairs Office at Fort Benning, Georgia, is a long-term champion of stereo photography. Several years ago, he created the book *Back to Basics: Infantry One Station Unit Training in 3-D*, which contains 75 black-and-white stereo pairs of infantry soldiers in initial training at Fort Benning. This CD includes many more images taken during the creation of the book as part of a historical collection of more than 1,000 modern stereo pairs and anaglyphs.

It is DOS/WIN, MAC, and UNIX compatible. A lorgnette viewer and a pair of anaglyph glasses, required for viewing in stereo, are included with every copy. The only system requirement is that you have an Internet Browser and can display at least 256 colors at 800x600 screen resolution.

RECENT AND RECOMMENDED

***The Memoirs of an Artillery Forward Observer 1944-1945.* By James Russell Major. Sunflower University Press, 1999. 152 Pages. \$18.95, Softbound.**

***Death Valley: The Summer Offensive, I Corps, August 1969.* By Keith William Nolan. Originally published in 1987. Presidio, 1999. 352 Pages. \$18.95, Softbound.**

***Into Cambodia.* By Keith William Nolan. Originally published in 1990. Presidio, 1999. 496 Pages. \$18.95, Softbound.**

***Guide to the Vicksburg Campaign.* U.S. Army War College Guides to Civil War Battles. Edited by Leonard Fullenkamp, Jay Luvaas, and Stephen Bowman. University Press of Kansas, 1998. 482 Pages. \$39.95, Hardcover; \$17.95, Softbound.**

***The Biographical Dictionary of World War II.* By Mark M. Boatner III. Hardcover edition published in 1996. Presidio, 1999. 736 Pages. \$24.95, Softbound.**

***Iron Knights: The United States 66th Armored Regiment.* By Gordon A. Blaker. White Mane Publishing (P.O. Box 152, Shippensburg, PA 17257), 1999. 411 Pages. \$39.95.**

***Beyond the Paths of Heaven: The Emergence of Space Power Thought.* By The School of Advanced Airpower Studies. Air University Press (Maxwell AFB, Alabama), 1999. 572 Pages.**

***Six Armies in Tennessee: The Chickamauga and Chattanooga Campaigns.* By Steven E. Woodworth. Hardcover edition published in 1998. University of Nebraska Press, 1999. 257 Pages. \$14.95, Softbound.**

From the Editor

SHARING THE EXPERTISE

As we proceed with the structure and fielding of the Initial Medium Combat Brigade, we need your input, and not only on the tactics and types of vehicles that will carry us into battle. In this issue of *Infantry*, you will see articles on the logistical skills we will need to support the new organization. These principles are nothing new, but they apply as much to the new brigade as to the units we train with every day. If we expect our forward deployed units to fully exploit the advantages in maneuverability and firepower that we envision for them, we must establish—and maintain—the sustainment systems needed to support tomorrow's fast-paced operations. We cannot wait until a helicopter goes down or a unit gets cut off to figure out how to reinforce or re-supply them. We must plan—and train—for that now.

The discussion of weapons and ammunition—always a lively subject among infantrymen—has led to improvements and enabled us to outstrip our adversaries for over a century. The infantryman more than anyone deals with realities of his profession. If he can hit and kill or neutralize his adversary with the first shot, we have trained and equipped him as we should. We all know that a soldier's confidence in his rifle is indispensable to the profession of arms, and we build and sustain that confidence by continually improving our weapons and ammunition and refining our training. As we look increasingly toward military operations in built-up areas, we need to look for ways to simplify the problems of ammunition resupply, while demanding increased ballistic performance. Commonality of rifle and machinegun ammunition deserves continued attention, and Mr. Stanley C. Crist's excellent article on the 6mm cartridge offers some insights on this subject.

Officer candidate school (OCS) commissions over 600 officers in all branches annually, and we have included a historical perspective on the OCS program that gave us so much of our junior officer leadership during World War II. The course content in those days was driven to a large extent by the war that was already under way, and today's program of instruction likewise addresses the realities of environments in which graduates will have to serve.

As a member of the Infantry community, you have the experience and expertise that can be of tremendous use to others, and I encourage you to write, e-mail, or call about joining the long list of professional soldiers who have seen their material published in *Infantry*. Two important things to remember: First, if your article requires a map, please provide one that includes all of the places and terrain features mentioned in your text. A good map is a tremendous aid to the reader, but one that does not include all of the information only frustrates him and causes him to lose interest. Secondly, explain all acronyms. The best solution is to use the commonly understood acronyms found in FM 101-5-1, *Operational Terms and Graphics*, or in AR 310-50, *Authorized Abbreviations, Brevity Codes, and Acronyms*. Remember that the reader should be able to understand an article in a single, rapid reading. If he cannot, he will simply ignore the product of so much of your hard work and go on to something else.

In this and in future issues of *Infantry*, you will not see a whole lot of theoretical monologue on proposals and equipment that will never see the light of day. What you will see is common-sense solutions to the problems of logistics, training, and tactics that our predecessors faced, and that continue to beset us. You will also see an occasional historical piece that illustrates a relevant lesson. The lessons of the past were often learned at enormous cost—in terms of both human life and materiel—and we can ill afford to ignore those lessons. Watch your lane.

RAE

SUBSCRIPTION INFORMATION

INFANTRY is available to subscribers at \$15.00 for six issues and \$28.00 for twelve issues. Foreign (non-APO) subscribers must add \$5.00 per subscription per year to cover the cost of surface mailing and handling. Foreign air mail rates will be furnished upon request. Single copies are \$2.50 each if sent to a U.S. address.

Payment must be made in U.S. currency, by international money order, or by a check or draft drawn on a U.S. bank. For best service, payment should accompany each order, because we cannot start a subscription until we have received full payment for it. Checks, money orders, or drafts should be made payable to INFANTRY.

COMING ARTICLES:

**Brigade Reconnaissance Troop
The Commander and the Chaplain
Sergeant Houston Wilson, Korea 1952
Tenth Mountain Division in World War II
Short Range Training Rounds for Mortars
Platoon Breach in Support of MOUT Attack**



PIN: 078056-000

DEPARTMENT OF THE ARMY
INFANTRY (USPS 370630)
U.S. Army Infantry School
ATTN: ATSH-OTI
Fort Benning, Georgia 31905-5593

OFFICIAL BUSINESS

PRESORTED STANDARD
U.S. POSTAGE
PAID
TEMPLE HILLS, MD
PERMIT NO. 4820